

Volvo Construction Equipment
Building Tomorrow



EC250E HYBRID

Volvo Excavators



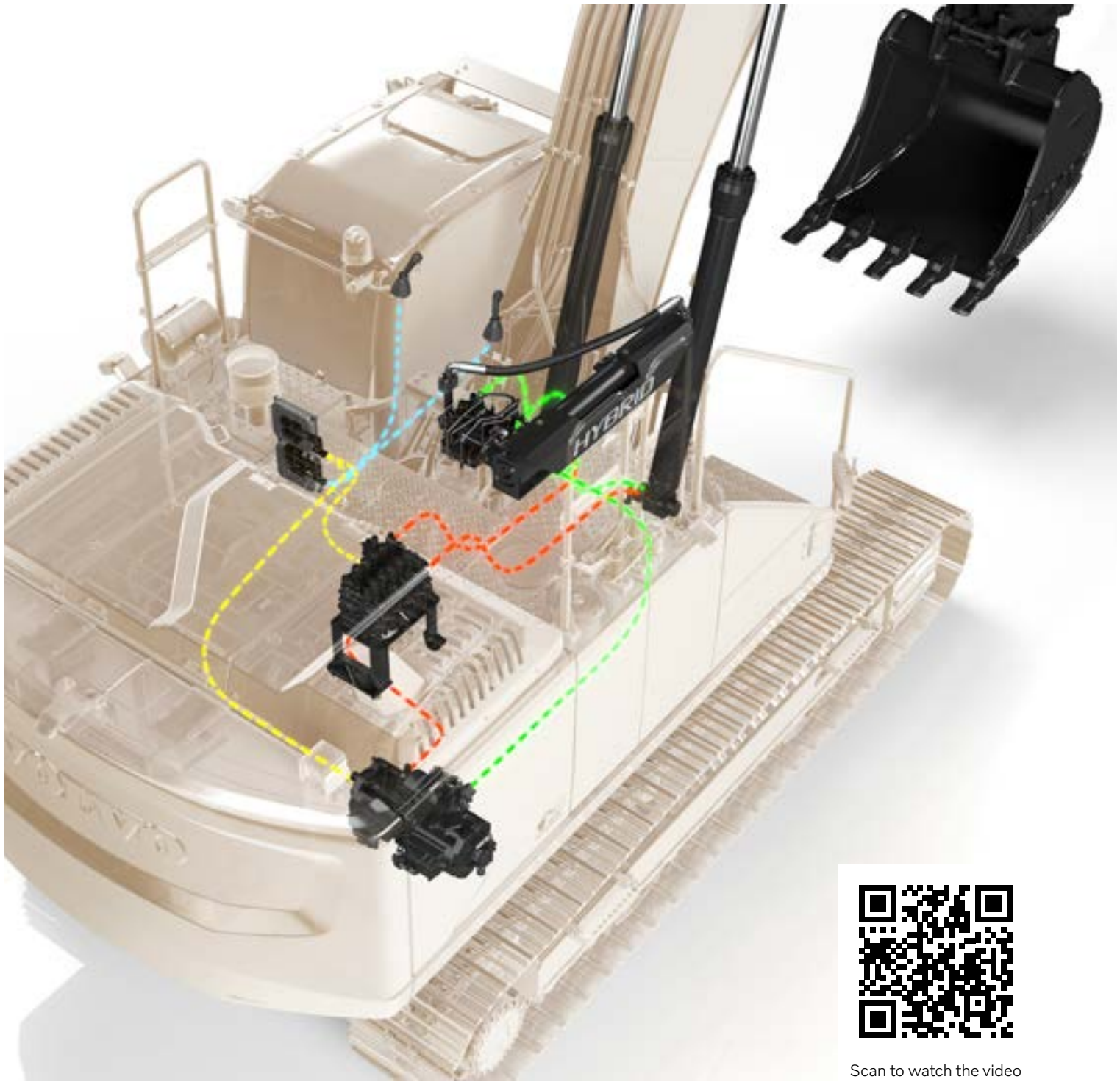

Scan to watch the video

Simple solution, big savings

Introducing the new EC250E Hybrid. Featuring unique hydraulic hybrid Volvo technology, the excavator utilizes the boom down motion to charge the accumulator, with the stored energy used to drive the assist motor, which powers the engine system.

The result is up to 17%* increase in fuel efficiency while delivering all the power and performance you would expect from a conventional EC250E.

*Efficiency and savings may vary based on operator, application and conditions.



17%
greater fuel
efficiency*



15%
lower fuel
consumption*

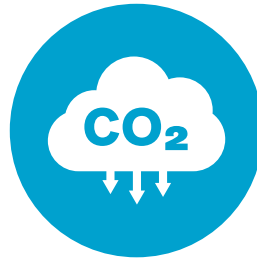

15%
reduction in
CO₂ emissions*



100%
Volvo engineered
hydraulic hybrid

Simply reliable

The uncomplicated and reliable hybrid solution is easy to maintain and consists of just a handful of add-on components, meaning no disruption or complication to how the high performing EC250E is engineered.



Cleaner and greener

The EC250E Hybrid reduces CO₂ emissions by up to 15%* making it a more environmentally respectful choice, especially when working in built-up areas.

Rapid payback

When working in dig and dump applications, the EC250E Hybrid is a straightforward solution with fast payback. Save fuel, lower emissions and boost the profitability of your operation.

EC250E Hybrid in detail

Engine

The next-generation Volvo diesel engine uses Volvo Advanced Combustion Technology (V-ACT) to deliver lower emissions, superior performance and fuel efficiency. The engine uses precise, highpressure fuel injectors, turbo charger and intercooler, and electronic engine controls to optimize machine performance.

Engine	Volvo	D8M
Max power at	r/min	1 600
Net, ISO 9249/SAE J1349	kW	167
	hp	227
Gross, ISO 14396/SAE J1995	kW	168
	hp	228
Max torque	Nm	1 166
at engine speed	r/min	1 350
No. of cylinders		6
Displacement	l	7.7
Bore	mm	110
Stroke	mm	135

Hybrid

The uncomplicated and reliable hybrid solution, Volvo's novel hydraulic hybrid harvests 'free' energy generated by the down motion of the excavator's boom and uses it to supercharge the engine system. The powerful and regular boom-down motions charge the 20 litre hydraulic accumulator (5.3 gallon), which then delivers energy to drive the hydraulic assist motor that helps to power the engine system. There are the same levels of controllability and performance as the standard EC250E, including the ability to work in ECO mode and Hybrid mode simultaneously.

Accumulator

No. of accumulator		1
Displacement	l	20

Electrical System

High-capacity electrical system that is well protected. Waterproof double-lock harness plugs are used to secure corrosion-free connections. The main relays and solenoid valves are shielded to prevent damage. The master switch is standard.

Voltage	V	24
Batteries	V	2 x 12
Battery capacity	Ah	170
Alternator	V/A	28 / 80
Start motor	V - kW	24 - 5.5

Undercarriage

The undercarriage has a robust X-shaped frame. Greased and sealed track chains are standard.

Track shoes		2 x 51
Link pitch	mm	190
Shoe width	mm	600 / 700 / 800 / 900
Shoe width, triple grouser	mm	600 / 700 / 800 / 900
Shoe width, triple grouser (HD)	mm	600
Shoe width, double grouser	mm	600 / 700
Bottom rollers		2 x 9
Top rollers		2 x 2

Cab

The operator's cab has easy access via a wide door opening. The cab is supported on hydraulic dampening mounts to reduce shock and vibration levels. These along with sound absorbing lining provide low noise levels. The cab has excellent all-round visibility. The front windshield can easily slide up into the ceiling, and the lower front glass can be removed and stored in the side door.

Refrigerant of the type R134a is used when this machine is equipped with air conditioning. Contains fluorinated greenhouse gas R134a, Global Warming Potential 1.430 t CO₂-eq.

Swing system

The swing system uses an axial piston motors, driving a planetary gearbox for maximum torque. An automatic holding brake and anti-rebound valve are standard.

Max. slew speed	r/min	11.7
Max. slew torque	kNm	91.7

Travel System

Each track is powered by an automatic two-speed shift travel motor. The track brakes are multi-disc, spring-applied and hydraulic released. The travel motor, brake and planetary gears are well protected within the track frame.

Max. drawbar pull	kN	217
Max. travel speed (low)	km/h	3.5
Max. travel speed (high)	km/h	5.5
Gradeability	°	35

Sound Level

Sound pressure level in cab according to ISO 6396

L _{pA}	dB	70
-----------------	----	----

External sound level according to ISO 6395 and EU Noise Directive 2000/14/EC

L _{WA}	dB	104
-----------------	----	-----

Hydraulic system

The hydraulic system, also known as the "Automatic Sensing Work Mode," is designed for high-productivity, high-digging capacity, high-maneuvering precision and excellent fuel economy. The summation system, boom, arm and swing priority along with boom, arm and bucket regeneration provides optimum performance.

Main pump, Type 2 x Variable displacement axial piston pumps

Maximum flow	l/min	2 x 240
--------------	-------	---------

Pilot pump, Type Gear Pump

Maximum flow	l/min	20.3
--------------	-------	------

Relief value setting pressure

Implement	MPa	33.3 / 36.3
Travel circuit	MPa	36.3
Slew circuit	MPa	27.9
Pilot circuit	MPa	3.9

Hydraulic Motors

Travel: Variable displacement axial piston motor with mechanical brake

Swing: Fixed displacement piston motor with mechanical brake

Hydraulic Cylinders

Mono boom		2
Bore x Stroke	ø x mm	135 x 1 345
Arm		1
Bore x Stroke	ø x mm	140 x 1 665
Bucket		1
Bore x Stroke	ø x mm	130 x 1 150

Service Refill

Fuel tank	l	472
DEF/AdBlue® tank	l	50
Hydraulic system, total	l	385
Hydraulic tank	l	215
Engine oil	l	30
Engine coolant	l	44
Slew reduction unit	l	5.9
Travel reduction unit	l	2 x 5

Specifications

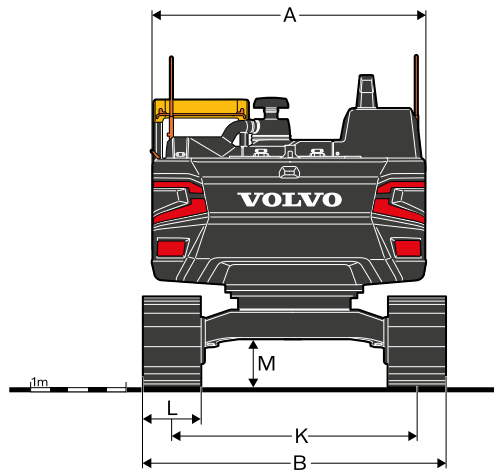
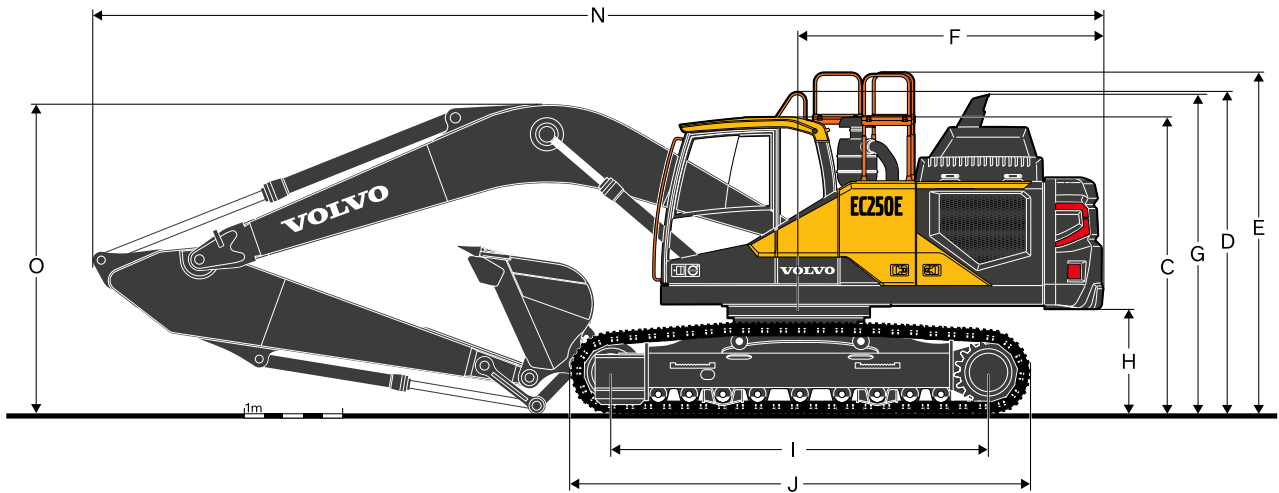

Description	Unit	EC250EL Hybrid			EC250ENL Hybrid		
		2.5	2.97	3.6	6.0		
Boom	m	6.0			6.0		
Arm	m	2.5	2.97	3.6	2.5	2.97	3.6
A. Overall width of upper structure	mm	2 890	2 890	2 890	2 890	2 890	2 890
B. Overall width	mm	3 190	3 190	3 190	2 990	2 990	2 990
C. Overall height of cab	mm	3 045	3 045	3 045	3 045	3 045	3 045
D. Overall height of handrail	mm	3 310	3 310	3 310	3 310	3 310	3 310
E. Overall height of guardrail (Unfolded)	mm	3 515	3 515	3 515	3 515	3 515	3 515
E'. Overall height of handrail/guardrail (Folded)	mm	3 035	3 035	3 035	3 035	3 035	3 035
F. Tail swing radius	mm	3 075	3 075	3 075	3 075	3 075	3 075
G. Overall height of diffuser	mm	3 135	3 135	3 135	3 135	3 135	3 135
H. Counterweight clearance *	mm	1 045	1 045	1 045	1 045	1 045	1 045
I. Tumbler length	mm	3 850	3 850	3 850	3 850	3 850	3 850
J. Track length	mm	4 650	4 650	4 650	4 650	4 650	4 650
K. Track gauge	mm	2 590	2 590	2 590	2 390	2 390	2 390
L. Shoe width	mm	600	600	600	600	600	600
M. Min. ground clearance *	mm	470	470	470	470	470	470
N. Overall length	mm	10 310	10 230	10 300	10 310	10 230	10 300
O. Overall height of boom	mm	3 330	3 110	3 330	3 330	3 110	3 330

* Without shoe grouser

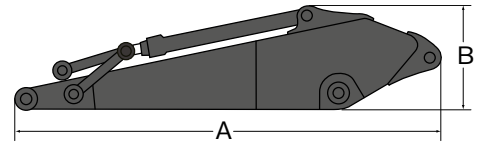
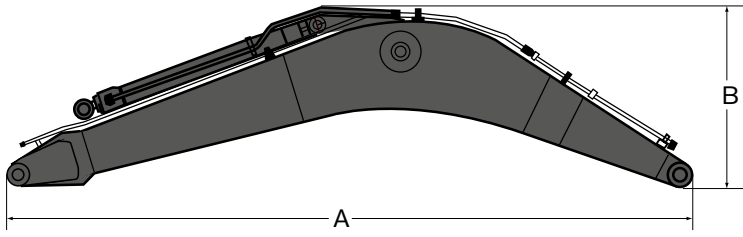

DIMENSIONS

Description	Unit			Description	Unit				
Boom	m	6.0 GP	6.0 HD	Arm	m	2.5 HD	2.97 GP	2.97 HD	3.6 GP
Length	mm	6 220	6 220	Length	mm	3 580	4 050	4 050	4 715
Height	mm	1 750	1 750	Height	mm	995	995	995	1 000
Width	mm	725	725	Width	mm	510	510	510	510
Weight	kg	2 230	2 355	Weight	kg	1 210	1 245	1 300	1 335

* Includes cylinder, piping and pin, excludes boom cylinder pin

* Includes cylinder, linkage and pin

Specifications

WORKING RANGES						
Description		Unit	EC250EL / EC250ENL Hybrid			
Boom		m	6.0			
Arm		m	2.5	2.97	3.6	
A. Max. digging reach		mm	9 960	10 340	10 810	
B. Max. digging reach on ground		mm	9 775	10 160	10 640	
C. Max. digging depth		mm	6 590	7 060	7 690	
D. Max. digging depth (2.44 m level)		mm	6 375	6 855	7 470	
E. Max. vertical wall digging depth		mm	5 265	5 520	5 805	
F. Max. cutting height		mm	9 620	9 685	9 645	
G. Max. dumping height		mm	6 610	6 710	6 730	
H. Min. front swing radius		mm	3 915	3 890	3 890	
DIGGING FORCES WITH DIRECT FIT BUCKET						
Bucket radius		mm	1 620	1 620	1 620	
Breakout force	Normal	SAE J1179	kN	145	145	145
	Power boost		kN	157	157	157
	Normal	ISO 6015	kN	166	166	166
	Power boost		kN	181	181	181
Tearout force	Normal	SAE J1179	kN	132	114	102
	Power boost		kN	143	124	111
	Normal	ISO 6015	kN	136	118	105
	Power boost		kN	148	128	114
Rotation angle, bucket		°	177	177	177	

MACHINE WITH MONO BOOM

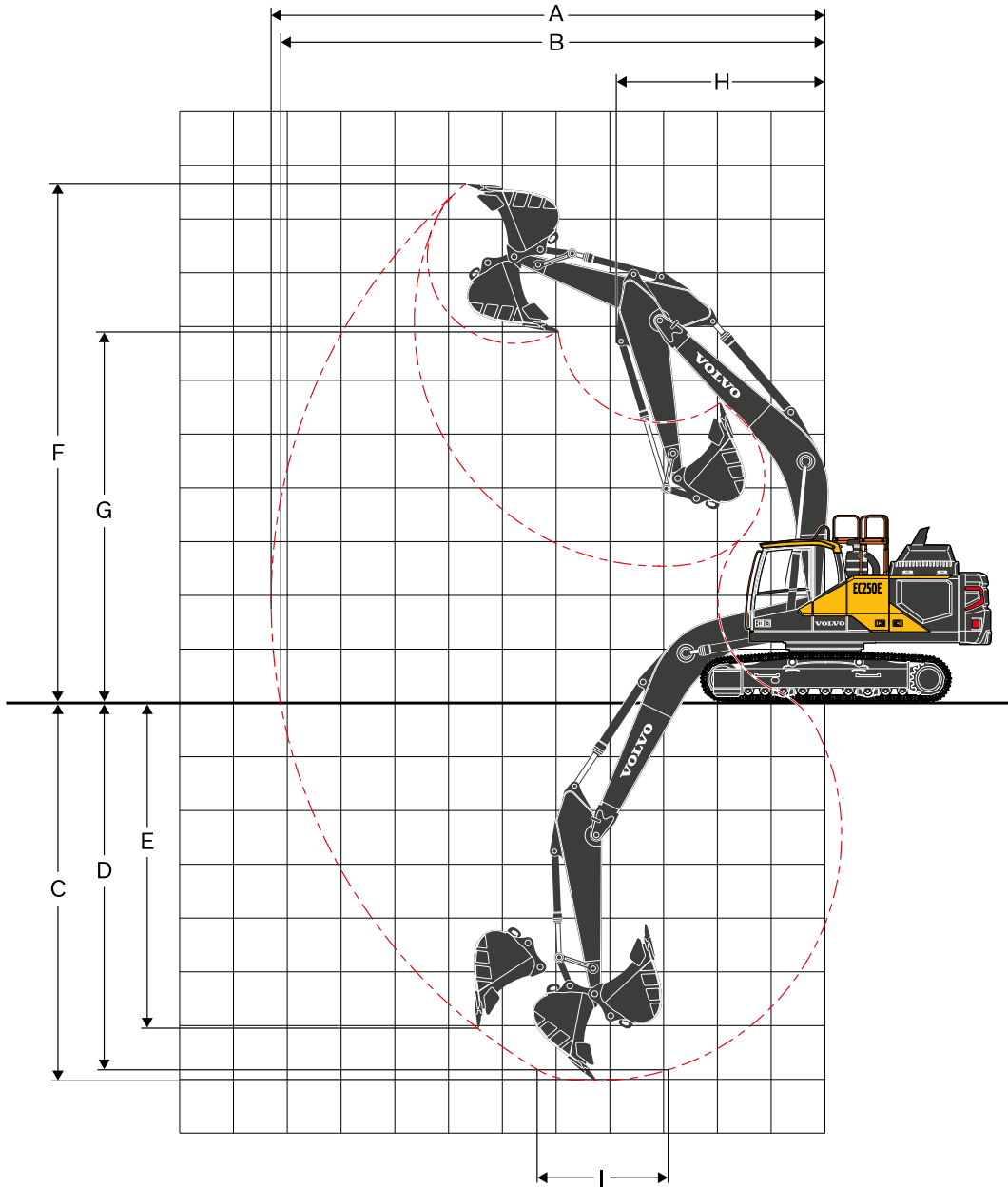

Specifications

MACHINE WEIGHTS AND GROUND PRESSURE

Description	Shoe width	Operating weight	Ground pressure	Overall width	Operating weight	Ground pressure	Overall width
	mm	kg	kPa	mm	kg	kPa	mm
EC250EL Hybrid							
		6.0 m boom (GP), 2.97 m arm (GP), 1 200 kg / 1.14 m³ bucket, 4 950 kg counterweight			6.0 m boom (HD), 2.97 m arm (HD), 1 200 kg / 1.14 m³ bucket, 4 950 kg counterweight		
Triple grouser	600	27 230	53.8	3 190	27 410	54.1	3 190
	600 (HD)	27 470	54.3	3 190	27 650	54.6	3 190
	700	27 530	46.6	3 290	27 710	46.9	3 290
	800	27 820	41.2	3 390	28 000	41.5	3 390
	900	28 130	37.0	3 490	28 310	37.3	3 490
Double grouser	600	27 450	54.2	3 290	27 630	54.6	3 190
	700	27 790	47.1	3 290	27 970	47.4	3 290
EC250ENL Hybrid							
		6.0 m boom (GP), 2.97 m arm (GP), 1 200 kg / 1.14 m³ bucket, 4 950 kg counterweight			6.0 m boom (HD), 2.97 m arm (HD), 1 200 kg / 1.14 m³ bucket, 4 950 kg counterweight		
Triple grouser	600	27 150	53.6	2 990	27 320	54.0	2 990
	600 (HD)	27 390	54.1	2 990	27 560	54.4	2 990
	700	27 450	46.5	3 090	27 620	46.8	3 090
	800	27 740	41.1	3 190	27 910	41.4	3 190
	900	28 050	36.9	3 290	28 220	37.2	3 290
Double grouser	600	27 370	54.1	2 990	27 540	54.4	2 990
	700	27 710	46.9	3 090	27 880	47.2	3 090

BUCKET SELECTION GUIDE

Bucket type		Capacity	Cutting width	Weight	Teeth	EC250EL Hybrid			EC250ENL Hybrid		
						600 mm shoe, 4 950 kg counterweight			600 mm shoe, 4 950 kg counterweight		
						6.0 m GP Boom			6.0 m GP Boom		
						L	mm	kg	EA	2.5 m	2.97 m
Direct fit bucket	General purpose	560	600	800	3	C	C	C	C	C	C
		620	750	823	3	C	C	C	C	C	C
		770	900	983	4	C	C	C	C	C	C
		950	1 090	1 012	4	C	C	C	C	C	C
		1 140	1 240	1 179	5	C	C	C	C	C	C
		1 320	1 390	1 196	5	C	C	C	C	C	C
		1 450	1 490	1 249	5	C	C	C	C	C	B
		1 510	1 540	1 294	5	C	C	C	C	C	B
	1 760	1 740	1 435	6	C	B	B	B	B	A	
	Heavy duty	560	600	870	3	D	D	D	D	D	D
		620	750	880	3	D	D	D	D	D	D
		1 140	1 240	1 200	5	D	D	D	D	D	D
		1 320	1 390	1 289	5	D	D	D	D	D	C
		1 510	1 540	1 377	5	D	D	C	C	C	B
1 760		1 740	1 533	6	C	B	A	B	A	B	
Direct fit bucket (UQC interface)	General purpose	560	600	800	3	C	C	C	C	C	C
		620	750	823	3	C	C	C	C	C	C
		770	900	983	4	C	C	C	C	C	C
		950	1 090	1 012	4	C	C	C	C	C	C
		1 140	1 240	1 179	5	C	C	C	C	C	B
		1 320	1 390	1 196	5	C	C	C	C	B	B
		1 450	1 490	1 249	5	C	C	B	B	B	A
		1 510	1 540	1 294	5	C	B	A	B	B	X
	1 760	1 740	1 435	6	B	A	X	A	X	X	
	Heavy duty	560	600	870	3	D	D	D	D	D	D
		620	750	880	3	D	D	D	D	D	D
		1 140	1 240	1 200	5	D	D	D	D	D	B
		1 320	1 390	1 289	5	D	C	B	C	B	A
		1 510	1 540	1 377	5	C	B	A	B	A	X
1 760		1 740	1 533	6	B	A	X	A	X	X	

Please consult with your Volvo dealer for the proper match of buckets and attachments to suit the application.

The recommendations are given as a guide only, based on typical operation conditions.

Bucket capacity based on ISO 7451, heaped material with a 1:1 angle of repose.

Maximum material density

A	1 200~1 300 kg/m ³	Coal, Caliche, Shale
B	1 400~1 600 kg/m ³	Wet earth and clay, Limestone, Sandstone
C	1 700~1 800 kg/m ³	Granite, Wet sand, Well blasted rock
D	> 1 900 kg/m ³	Wet mud, Iron ore
X	Not recommended	

Specifications

LIFTING CAPACITY EC250EL Hybrid

Lifting capacity at the arm end without bucket.

For lifting capacity including bucket, simply subtract actual weight of the direct fit bucket or the bucket with quick coupler from the following values.

	Lifting point	1.5 m		3.0 m		4.5 m		6.0 m		7.5 m		9.0 m		Max. reach															
		Along UC	Across UC	Along UC	Across UC	Along UC	Across UC	Along UC	Across UC	Along UC	Across UC	Along UC	Across UC	Along UC	Across UC	m													
Boom: 6.0 m Arm: 2.5 m Shoe: 600 mm CWT: 4 950 kg	7.5 m	kg							*6 890	*6 890					*6 940	*6 940	6.1												
	6.0 m	kg							*6 900	*6 900					*6 930	5 540	7.2												
	4.5 m	kg							*7 740	7 250	*7 100	5 140			6 960	4 720	7.9												
	3.0 m	kg							*12 020	10 510	*8 950	6 930	7 430	5 000	6 400	4 320	8.3												
	1.5 m	kg							*14 100	9 930	*10 090	6 630	7 270	4 850	6 230	4 180	8.3												
	0 m	kg							*14 870	9 690	9 960	6 440	7 150	4 750	6 400	4 270	8.1												
	-1.5 m	kg													7 000	4 650	7.6												
	-3.0 m	kg													8 450	5 550	6.7												
	-4.5 m	kg													*9 080	8 030	5.2												
Boom: 6.0 m Arm: 2.97 m Shoe: 600 mm CWT: 4 950 kg	7.5 m	kg													*6 080	*6 080	6.6												
	6.0 m	kg							*6 330	*6 330	*6 390	5 300			*5 830	5 120	7.7												
	4.5 m	kg							*8 430	*8 430	*7 220	*7 220	*6 670	5 210	*5 860	4 420	8.3												
	3.0 m	kg							*11 140	10 720	*8 490	7 020	*7 280	5 050	6 010	4 070	8.6												
	1.5 m	kg							*13 500	10 070	*9 740	6 700	7 300	4 890	5 850	3 940	8.7												
	0 m	kg							*5 020	*5 020	*14 680	9 730	9 990	6 470	7 160	4 760	8.5												
	-1.5 m	kg													6 470	4 310	8.0												
	-3.0 m	kg													7 610	5 020	7.2												
	-4.5 m	kg													*8 940	6 810	5.8												
Boom: 6.0 m Arm: 3.6 m Shoe: 600 mm CWT: 4 950 kg	7.5 m	kg													*5 040	*5 040	7.2												
	6.0 m	kg													*4 900	4 640	8.2												
	4.5 m	kg													*4 950	4 060	8.8												
	3.0 m	kg													*15 760	*15 760	*9 850	*9 850	*7 750	7 110	*6 750	5 090	*5 650	3 830	*5 180	3 750	9.1		
	1.5 m	kg													*12 490	10 210	*9 130	6 740	7 320	4 890	5 560	3 730	5 400	3 630	9.2				
	0 m	kg													*7 080	*7 080	*14 150	9 740	9 990	6 460	7 140	4 730	5 490	3 660	9.0				
	-1.5 m	kg													*6 800	*6 800	*10 800	*10 800	*14 740	9 540	9 810	6 300	7 030	4 630	5 870	3 900	8.5		
	-3.0 m	kg													*11 030	*11 030	*16 000	*16 000	*14 400	9 520	9 760	6 260	7 020	4 620	6 730	4 440	7.7		
	-4.5 m	kg													*16 340	*16 340	*18 580	*18 580	*12 990	9 660	*9 600	6 360			*8 610	5 690	6.5		
-6.0 m	kg															*9 450	*9 450							*9 390	*9 390	4.5			
Boom: 6.0 m Arm: 2.5 m Shoe: 800 mm CWT: 4 950 kg	7.5 m	kg													*6 930	*6 930	6.1												
	6.0 m	kg													*6 910	5 640	7.2												
	4.5 m	kg													*9 310	*9 310	*7 730	7 390	*7 070	5 240			*7 040	4 810	7.9				
	3.0 m	kg													*11 980	10 690	*8 920	7 050	7 580	5 090			6 530	4 400	8.3				
	1.5 m	kg													*14 050	10 090	*10 050	6 750	7 410	4 940			6 350	4 250	8.3				
	0 m	kg													*14 800	9 840	10 150	6 550	7 290	4 830			6 520	4 340	8.1				
	-1.5 m	kg													*10 440	*10 440	*14 590	9 790	10 060	6 470	7 250	4 790			7 130	4 720	7.6		
	-3.0 m	kg													*18 580	*18 580	*13 480	9 890	*10 090	6 520			8 610	5 640	6.7				
	-4.5 m	kg													*14 840	*14 840	*10 830	10 170					*9 020	8 150	5.2				
Boom: 6.0 m Arm: 2.97 m Shoe: 800 mm CWT: 4 950 kg	7.5 m	kg													*6 050	*6 050	6.6												
	6.0 m	kg													*6 280	*6 280	*6 330	5 370					*5 800	5 180	7.7				
	4.5 m	kg															*8 390	*8 390	*7 170	*7 170	*6 620	5 280			*5 830	4 470	8.3		
	3.0 m	kg															*11 080	10 890	*8 430	7 120	*7 220	5 120			*6 070	4 110	8.6		
	1.5 m	kg															*13 410	10 200	*9 660	6 780	7 420	4 940			5 940	3 970	8.7		
	0 m	kg															*4 990	*4 990	*14 580	9 850	10 150	6 540	7 270	4 810	6 070	4 040	8.5		
	-1.5 m	kg															*6 640	*6 640	*10 660	*10 660	*14 700	9 740	10 020	6 430	7 200	4 740	6 570	4 350	8.0
	-3.0 m	kg															*12 320	*12 320	*17 740	*17 740	*13 930	9 780	10 030	6 440			7 720	5 070	7.2
	-4.5 m	kg															*16 570	*16 570	*11 890	10 000					*8 850	6 880	5.8		
Boom: 6.0 m Arm: 3.6 m Shoe: 800 mm CWT: 4 950 kg	7.5 m	kg													*5 040	*5 040	7.2												
	6.0 m	kg													*5 640	5 500	8.2												
	4.5 m	kg													*6 420	*6 420	*6 050	5 380					*4 950	4 140	8.8				
	3.0 m	kg															*15 730	*15 730	*9 830	*9 830	*7 730	7 250	*6 730	5 190	*5 650	3 900	*5 180	3 820	9.1
	1.5 m	kg															*12 450	10 390	*9 100	6 860	7 470	4 980	5 670	3 800	5 510	3 690	9.2		
	0 m	kg															*7 080	*7 080	*14 100	9 900	*10 160	6 570	7 280	4 810	5 600	3 730	9.0		
	-1.5 m	kg															*6 800	*6 800	*10 800	*10 800	*14 670	9 690	10 000	6 400	7 170	4 710	5 980	3 960	8.5
	-3.0 m	kg															*11 030	*11 030	*16 000	*16 000	*14 330	9 670	9 950	6 360	7 160	4 700	6 850	4 510	7.7
	-4.5 m	kg															*16 340	*16 340	*18 470	*18 470	*12 920	9 810	*9 550	6 460			*8 560	5 770	6.5
-6.0 m	kg																	*9 380	*9 380					*9 330	*9 330	4.5			

Notes: 1. Machine in "Fine Mode-F" (Power Boost) for lifting capacities. 2. The above loads are in compliance with SAE J1097 and ISO 10567 Hydraulic Excavator Lifting Capacity Standards. 3. Rated loads do not exceed 87% of hydraulic lifting capacity or 75% of tipping load. 4. Rated loads marked with an asterisk (*) are limited by hydraulic capacity rather than tipping load.

LIFTING CAPACITY EC250ENL Hybrid

Lifting capacity at the arm end without bucket.

For lifting capacity including bucket, simply subtract actual weight of the direct fit bucket or the bucket with quick coupler from the following values.

	Lifting point	1.5 m		3.0 m		4.5 m		6.0 m		7.5 m		9.0 m		Max. reach		
		Along UC	Across UC	Along UC	Across UC	Along UC	Across UC	Along UC	Across UC	Along UC	Across UC	Along UC	Across UC	Along UC	Across UC	m
Boom: 6.0 m Arm: 2.5 m Shoe: 600 mm CWT: 4 950 kg	7.5 m kg							*6 890	*6 890					*6 940	6 750	6.1
	6.0 m kg							*6 900	*6 900					*6 930	5 110	7.2
	4.5 m kg					*9 320	*9 320	*7 740	6 670	*7 100	4 740			6 940	4 350	7.9
	3.0 m kg					*12 020	9 560	*8 950	6 360	7 410	4 600			6 380	3 970	8.3
	1.5 m kg					*14 100	9 000	*10 090	6 070	7 250	4 450			6 210	3 840	8.3
	0 m kg					*14 870	8 760	9 930	5 880	7 130	4 350			6 380	3 910	8.1
	-1.5 m kg			*10 440	*10 440	*14 660	8 730	9 850	5 810	7 100	4 320			6 980	4 260	7.6
	-3.0 m kg			*18 690	17 210	*13 560	8 820	9 910	5 870					8 420	5 080	6.7
	-4.5 m kg			*14 940	*14 940	*10 900	9 090							*9 080	7 320	5.2
Boom: 6.0 m Arm: 2.97 m Shoe: 600 mm CWT: 4 950 kg	7.5 m kg													*6 080	6 040	6.6
	6.0 m kg							*6 330	*6 330	*6 390	4 900			*5 830	4 720	7.7
	4.5 m kg					*8 430	*8 430	*7 220	6 780	*6 670	4 810			*5 860	4 070	8.3
	3.0 m kg					*11 140	9 760	*8 490	6 450	*7 280	4 650			5 990	3 740	8.6
	1.5 m kg					*13 500	9 130	*9 740	6 130	7 280	4 480			5 830	3 610	8.7
	0 m kg			*5 020	*5 020	*14 680	8 800	9 960	5 910	7 140	4 360			5 960	3 670	8.5
	-1.5 m kg	*6 670	*6 670	*10 700	*10 700	*14 820	8 700	9 830	5 800	7 070	4 300			6 450	3 940	8.0
	-3.0 m kg	*12 360	*12 360	*17 780	17 030	*14 040	8 750	9 850	5 810					7 590	4 600	7.2
	-4.5 m kg			*16 720	*16 720	*12 000	8 950							*8 940	6 220	5.8
Boom: 6.0 m Arm: 3.6 m Shoe: 600 mm CWT: 4 950 kg	7.5 m kg													*5 040	*5 040	7.2
	6.0 m kg									*5 650	4 990			*4 900	4 290	8.2
	4.5 m kg							*6 430	*6 430	*6 060	4 870			*4 950	3 740	8.8
	3.0 m kg			*15 760	*15 760	*9 850	*9 850	*7 750	6 530	*6 750	4 680	5 640	3 520	*5 180	3 450	9.1
	1.5 m kg					*12 490	9 270	*9 130	6 170	7 300	4 490	5 540	3 420	5 380	3 330	9.2
	0 m kg			*7 080	*7 080	*14 150	8 810	9 960	5 900	7 120	4 330			5 470	3 360	9.0
	-1.5 m kg	*6 800	*6 800	*10 800	*10 800	*14 740	8 610	9 780	5 740	7 010	4 230			5 850	3 560	8.5
	-3.0 m kg	*11 030	*11 030	*16 000	*16 000	*14 400	8 600	9 730	5 700	7 000	4 220			6 710	4 060	7.7
	-4.5 m kg	*16 340	*16 340	*18 580	17 010	*12 990	8 740	*9 600	5 800					*8 610	5 190	6.5
-6.0 m kg					*9 450	9 110							*9 390	9 050	4.5	

Notes: 1. Machine in "Fine Mode-F" (Power Boost) for lifting capacities. 2. The above loads are in compliance with SAE J1097 and ISO 10567 Hydraulic Excavator Lifting Capacity Standards. 3. Rated loads do not exceed 87% of hydraulic lifting capacity or 75% of tipping load. 4. Rated loads marked with an asterisk (*) are limited by hydraulic capacity rather than tipping load.

Equipment

STANDARD EQUIPMENT

Engine

Turbocharged, 4 stroke diesel engine with water cooling, direct injection and charged air cooler that meets EU Stage V requirements

Air filter with indicator

Air intake heater

Cyclone pre-cleaner

Electric engine shut-off

Fuel filter and water separator

Fuel filler pump: 50 l/min, with automatic shut-off

Alternator, 80 A

Hybrid

Accumulator, 20 L

Boom regeneration valves

Assist motor

Main pump with PTO

Electric / Electronic control system

Advanced mode control system

Self-diagnostic system

Machine status indication

Engine speed sensing power control

Automatic idling system

Onetouch power boost

Safety stop/start function

Adjustable LCD color monitor

Master electrical disconnect switch

Engine restart prevention circuit

High-capacity LED lights:

- Frame-mounted 2

- Boom-mounted 1

Batteries, 2 x 12 V / 170 A

Start motor, 24 V / 5.5 kW

Frame

Access way with handrail

Tool storage area

Punched metal anti-slip plates

Counterweight: 4 950 kg

Undercarriage

Undercover (heavy-duty)

Hydraulic track adjusters

Greased and sealed track link

Track Guard

Hydraulic system

Boom up swing priority function

Boom travel priority function (Creep)

Boom down speed control

Hose rupture valve: boom & arm

Overload warning device

Automatic sensing hydraulic system

- Summation system

- Boom priority

- Arm priority

- Swing priority

ECO mode fuel saving technology

Boom, arm and bucket regeneration valves

Swing anti-rebound valves

Boom and arm holding valves

Multi-stage filtering system

Cylinder cushioning

Cylinder contamination seals

Auxiliary hydraulic valve

Automatic two-speed travel motors

Hydraulic oil, longlife oil 46

STANDARD EQUIPMENT

Cab and interior

ROPS (ISO 12117-2) certified cab

Silicon oil and rubber mounts with spring

Travel pedals and hand levers

Adjustable operator seat and joystick control console

Proportional joysticks with 3 switches

Heater & air-conditioner, automatic

Flexible antenna

Radio with MP3 & USB Jack with Bluetooth

Hydraulic safety lock lever

Cab, all-weather sound suppressed, includes:

- Cup holders

- Door locks

- Tinted glass

- Floor mat

- Horn

- Large storage area

- Pull-up type front window

- Removable lower windshield

- Seat belt

- Safety glass

- Sun screens, front, roof, rear

- Rain shield

- Windshield wiper with intermittent feature

Rear view camera

Side view camera

Master key

Track shoes

600 mm with triple grousers

Digging equipment

Boom: 6.0 m monoblock

Arm: 2.97 m

Manual centralized lubrication

OPTIONAL EQUIPMENT

Engine

Block heater: 120 V, 240 V

Oil bath pre-cleaner

Diesel coolant heater, 10 kW

Water separator with heater

Auto engine shutdown

Reversible fan

Delayed engine shutdown

Electric

Extra work lights (Halogen or LED):

- Cab-mounted 3

- Boom-mounted 1

- Counterweight-mounted 1

Green light beacon

Travel alarm

Anti-theft system

Rotating warning beacon

Smart connect for tilt rotator

Tilt rotator 3rd gen

Dig assist, smart connect

OPTIONAL EQUIPMENT

Undercarriage

Full track guard

Track shoes

700/800/900 mm with triple grousers

600 mm HD with triple grousers

600/700 mm with double grousers

Hydraulic system

CDC, Comfort Driving Control

Boom float function with HRV

Boom float function without HRV

Attachment management system (up to 32 programmable memories)

- Variable flow and pressure pre-setting

Hammer & shear, 1 and 2 pump flow

Additional return filter

Hydraulic piping:

- Slope & rotator

- Grapple

- Oil leak (drain) line

Quick coupler piping

Volvo hydraulic quick coupler S1

Volvo hydraulic quick coupler S2

Volvo hydraulic quick coupler U25

Volvo hydraulic quick coupler S70

Volvo hydraulic quick coupler SQ70 55

Volvo hydraulic quick coupler SQ70

Hydraulic oil, biodegradable 46

Hydraulic oil, longlife oil 32

Hydraulic oil, longlife oil 68

Straight travel pedal

OPTIONAL EQUIPMENT

Cab and interior

Fabric seat with heater

Fabric seat with heater and air suspension

Deluxe seat

High-strength one piece front windshield (P5A)

Opening top hatch

Falling object guard, FOG (fixed type or hinge type)

Frame-mounted

Cab-mounted

Cab-mounted falling object protective structure (FOPS)

Volvo smart view

Smoker kit (ashtray and lighter)

Safety net for front window

Lower wiper with intermittent control

Anti-vandalism kit

Specific key

Cleaning air gun

Digging equipment

Boom: 6.0 m monoblock, heavy duty

Arm: 2.5 m HD, 2.97 m HD, 3.6 m

Linkage with lifting eye

Machine controls

Dig Assist

Volvo Active Control (Semi-autonomous)

Please refer to separate Brochure for more details

Service

Tool kit, daily maintenance

Tool kit, full scale

Automatic lubrication system

SELECTION OF VOLVO OPTIONAL EQUIPMENT

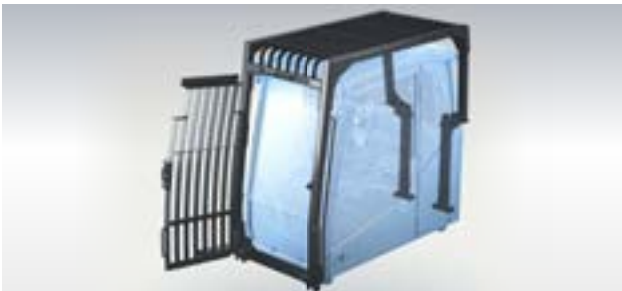
Swing out FOG**TiltRotator****Volvo Smart View****Comfort Drive Control**

Not all products are available in all markets. Under our policy of continuous improvement, we reserve the right to change specifications and design without prior notice. The illustrations do not necessarily show the standard version of the machine.

VOLVO

Volvo Construction Equipment

volvoce.com