

Volvo Construction Equipment
Building Tomorrow



EC300E HYBRID

Volvo Excavators



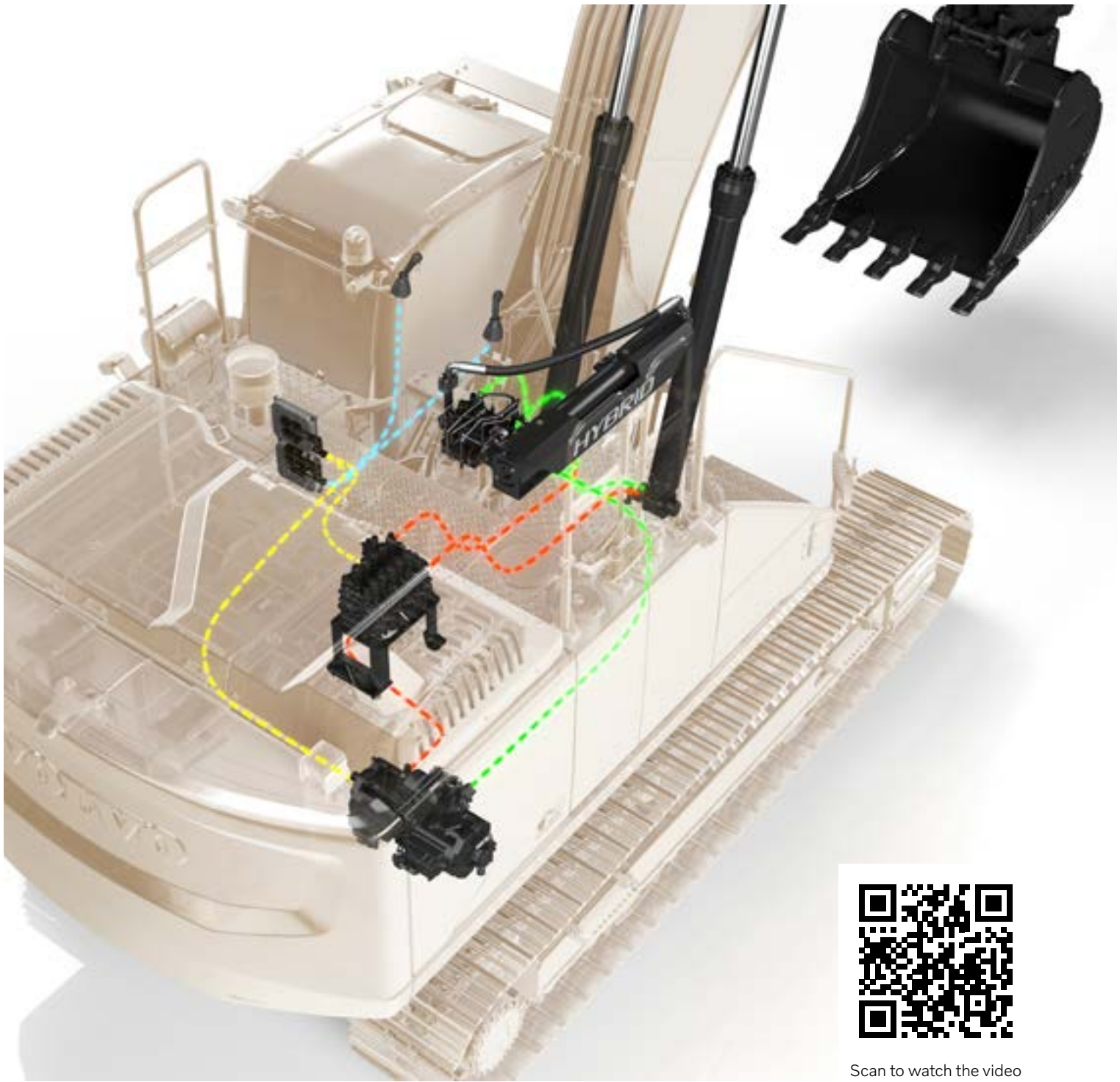

Scan to watch the video

Simple solution, big savings

Introducing the upgraded EC300E Hybrid. Featuring unique hydraulic hybrid Volvo technology, the excavator utilizes the boom down motion to charge the accumulator, with the stored energy used to drive the assist motor, which powers the engine system.

The result is up to 17%* increase in fuel efficiency while delivering all the power and performance you would expect from a conventional EC300E.

*Efficiency and savings may vary based on operator, application and conditions.



17%
greater fuel
efficiency*



15%
lower fuel
consumption*

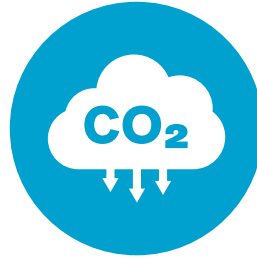

15%
reduction in
CO₂ emissions*



100%
Volvo engineered
hydraulic hybrid

Simply reliable

The uncomplicated and reliable hybrid solution is easy to maintain and consists of just a handful of add-on components, meaning no disruption or complication to how the high performing EC300E is engineered.



Cleaner and greener

The EC300E Hybrid reduces CO₂ emissions by up to 15%* making it a more environmentally respectful choice, especially when working in built-up areas.

Rapid payback

When working in dig and dump applications, the EC300E Hybrid is a straightforward solution with fast payback. Save fuel, lower emissions and boost the profitability of your operation.

EC300E Hybrid in detail

Engine

The next-generation Volvo diesel engine uses Volvo Advanced Combustion Technology (V-ACT) to deliver lower emissions, superior performance and fuel efficiency. The engine uses precise, highpressure fuel injectors, turbo charger and intercooler, and electronic engine controls to optimize machine performance.

Engine	Volvo	D8M
Max power at	r/min	1 600
Net, ISO 9249/SAE J1349	kW	188
	hp	256
Gross, ISO 14396/SAE J1995	kW	189
	hp	257
Max torque	Nm	1 290
at engine speed	r/min	1 400
No. of cylinders		6
Displacement	l	7.7
Bore	mm	110
Stroke	mm	135

Hybrid

The uncomplicated and reliable hybrid solution, Volvo's novel hydraulic hybrid harvests 'free' energy generated by the down motion of the excavator's boom and uses it to supercharge the engine system. The powerful and regular boom-down motions charge the 20 litre hydraulic accumulator (5.3 gallon), which then delivers energy to drive the hydraulic assist motor that helps to power the engine system. There are the same levels of controllability and performance as the standard EC300E, including the ability to work in ECO mode and Hybrid mode simultaneously.

Accumulator

No. of accumulator		1
Displacement	l	20

Electrical System

High-capacity electrical system that is well protected. Waterproof double-lock harness plugs are used to secure corrosion-free connections. The main relays and solenoid valves are shielded to prevent damage. The master switch is standard.

Voltage	V	24
Batteries	V	2 x 12
Battery capacity	Ah	170
Alternator	V/A	28 / 80
Start motor	V - kW	24 - 5.5

Undercarriage

The undercarriage has a robust X-shaped frame. Greased and sealed track chains are standard.

Track shoes		2 x 50
Link pitch	mm	203.2
Shoe width	mm	600 / 700 / 800 / 900
Shoe width, triple grouser	mm	600 / 700 / 800 / 900
Shoe width, triple grouser (HD)	mm	600
Shoe width, double grouser	mm	700
Bottom rollers		2 x 9
Top rollers		2 x 2

Cab

The operator's cab has easy access via a wide door opening. The cab is supported on hydraulic dampening mounts to reduce shock and vibration levels. These along with sound absorbing lining provide low noise levels. The cab has excellent all-round visibility. The front windshield can easily slide up into the ceiling, and the lower front glass can be removed and stored in the side door.

Refrigerant of the type R134a is used when this machine is equipped with air conditioning. Contains fluorinated greenhouse gas R134a, Global Warming Potential 1.430 t CO₂-eq.

Swing system

The swing system uses an axial piston motors, driving a planetary gearbox for maximum torque. An automatic holding brake and anti-rebound valve are standard.

Max. slew speed	r/min	11
Max. slew torque	kNm	114.8

Travel System

Each track is powered by an automatic two-speed shift travel motor. The track brakes are multi-disc, spring-applied and hydraulic released. The travel motor, brake and planetary gears are well protected within the track frame.

Max. drawbar pull	kN	248
Max. travel speed (low)	km/h	3.6
Max. travel speed (high)	km/h	5.4
Gradeability	°	35

Sound Level

Sound pressure level in cab according to ISO 6396

L _{pA}	dB	70
-----------------	----	----

External sound level according to ISO 6395 and EU Noise Directive 2000/14/EC

L _{WA}	dB	104
-----------------	----	-----

Hydraulic system

The hydraulic system, also known as the "Automatic Sensing Work Mode," is designed for high-productivity, high-digging capacity, high-maneuvering precision and excellent fuel economy. The summation system, boom, arm and swing priority along with boom, arm and bucket regeneration provides optimum performance.

Main pump, Type 2 x Variable displacement axial piston pumps

Maximum flow	l/min	2 x 276
--------------	-------	---------

Pilot pump, Type Gear Pump

Maximum flow	l/min	20.3
--------------	-------	------

Relief value setting pressure

Implement	MPa	33.3 / 36.3
Travel circuit	MPa	36.3
Slew circuit	MPa	28.9
Pilot circuit	MPa	3.9

Hydraulic Motors

Travel: Variable displacement axial piston motor with mechanical brake

Swing: Fixed displacement piston motor with mechanical brake

Hydraulic Cylinders

Mono boom		2
Bore x Stroke	ø x mm	140 x 1 480
Arm		1
Bore x Stroke	ø x mm	150 x 1 745
Bucket		1
Bore x Stroke	ø x mm	140 x 1 140

Service Refill

Fuel tank	l	472
DEF/AdBlue® tank	l	50
Hydraulic system, total	l	385
Hydraulic tank	l	215
Engine oil	l	30
Engine coolant	l	44
Slew reduction unit	l	6.1
Travel reduction unit	l	2 x 6

Specifications

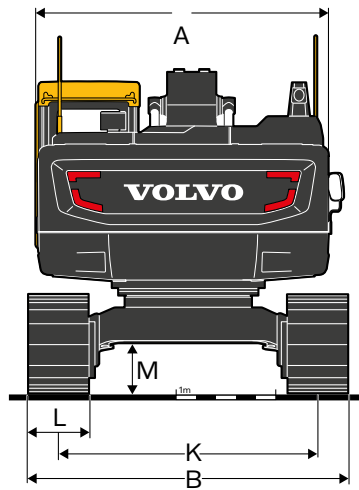
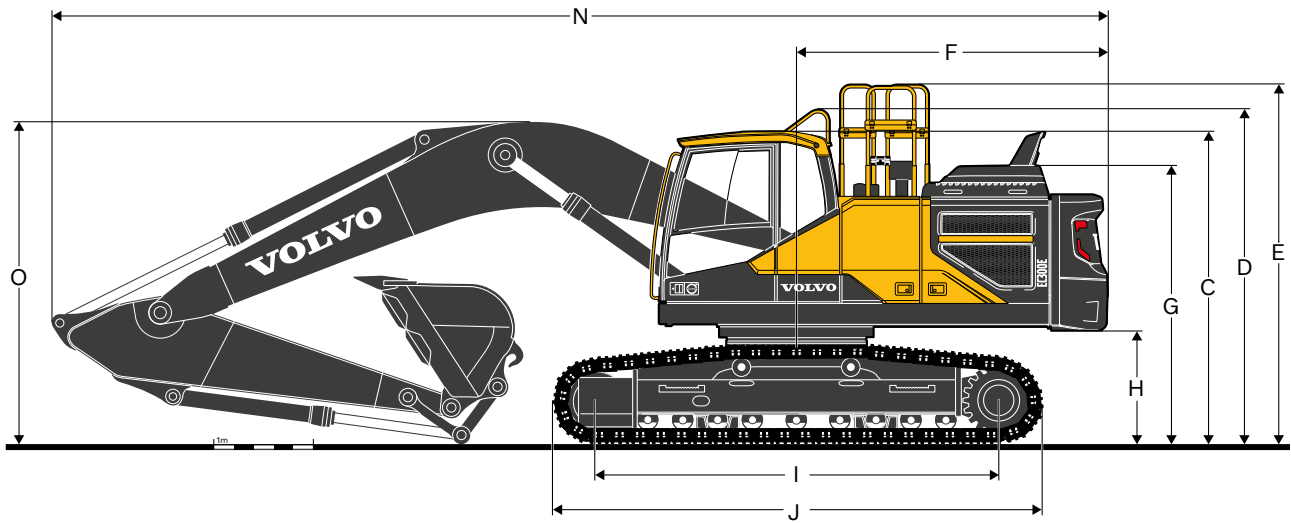

Description	Unit	EC300EL Hybrid			EC300ENL Hybrid		
		2.55	3.05	3.7	2.55	3.05	3.7
Boom	m	6.2			6.2		
Arm	m	2.55	3.05	3.7	2.55	3.05	3.7
A. Overall width of upper structure	mm	2 890	2 890	2 890	2 890	2 890	2 890
B. Overall width	mm	3 190	3 190	3 190	2 990	2 990	2 990
C. Overall height of cab	mm	3 110	3 110	3 110	3 110	3 110	3 110
D. Overall height of handrail	mm	3 360	3 360	3 360	3 360	3 360	3 360
E. Overall height of guardrail (Unfolded)	mm	3 570	3 570	3 570	3 570	3 570	3 570
E'. Overall height of handrail/guardrail (Folded)	mm	3 090	3 090	3 090	3 090	3 090	3 090
F. Tail swing radius	mm	3 120	3 120	3 120	3 120	3 120	3 120
G. Overall height of diffuser	mm	3 200	3 200	3 200	3 200	3 200	3 200
H. Counterweight clearance *	mm	1 105	1 105	1 105	1 105	1 105	1 105
I. Tumbler length	mm	4 015	4 015	4 015	4 015	4 015	4 015
J. Track length	mm	4 865	4 865	4 865	4 865	4 865	4 865
K. Track gauge	mm	2 590	2 590	2 590	2 390	2 390	2 390
L. Shoe width	mm	600	600	600	600	600	600
M. Min. ground clearance *	mm	475	475	475	475	475	475
N. Overall length	mm	10 605	10 500	10 540	10 605	10 500	10 540
O. Overall height of boom	mm	3 470	3 345	3 580	3 470	3 345	3 580

* Without shoe grouser

' 2-piece boom

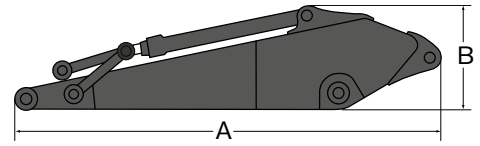
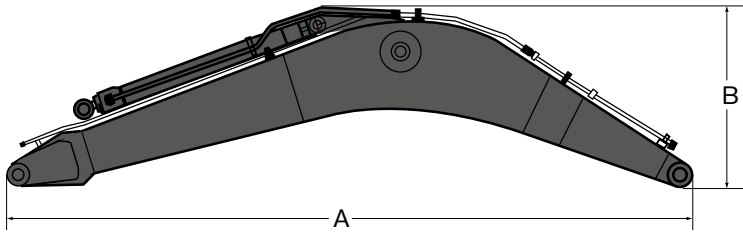

DIMENSIONS

Description	Unit	mono	mono
Boom	m	6.2 GP	6.2 HD
Length	mm	6 425	6 425
Height - Hose	mm	1 780	1 780
Height - Pipe	mm	1 665	1 665
Width	mm	765	765
Weight	kg	2 505	2 735

* Includes cylinder, piping and pin, excludes boom cylinder pin

Description	Unit	2.55 HD	3.05 GP	3.05 HD	3.7 GP
Arm	m				
Length	mm	3 720	4 145	4 145	4 800
Height	mm	1 005	1 010	1 010	1 005
Width	mm	560	560	560	560
Weight	kg	1 450	1 510	1 570	1 630

* Includes cylinder, linkage and pin

Specifications

WORKING RANGES						
Description		Unit	EC300EL / EC300ENL Hybrid			
Boom		m	6.2			
Arm		m	2.55	3.05	3.7	
A. Max. digging reach		mm	10 180	10 710	11 310	
B. Max. digging reach on ground		mm	9 970	10 520	11 130	
C. Max. digging depth		mm	6 840	7 340	7 990	
D. Max. digging depth (2.44 m level)		mm	6 600	7 150	7 830	
E. Max. vertical wall digging depth		mm	5 320	6 080	6 680	
F. Max. cutting height		mm	9 560	9 980	10 260	
G. Max. dumping height		mm	6 680	7 040	7 330	
H. Min. front swing radius		mm	4 220	4 180	4 240	
DIGGING FORCES WITH DIRECT FIT BUCKET						
Bucket radius		mm	1 624	1 624	1 624	
Breakout force	Normal	SAE J1179	kN	165	165	165
	Power boost		kN	179	179	179
	Normal	ISO 6015	kN	190	190	190
	Power boost		kN	207	207	207
Tearout force	Normal	SAE J1179	kN	158	133	116
	Power boost		kN	172	144	126
	Normal	ISO 6015	kN	163	136	118
	Power boost		kN	177	148	129
Rotation angle, bucket		°	179	179	179	

MACHINE WITH MONO BOOM

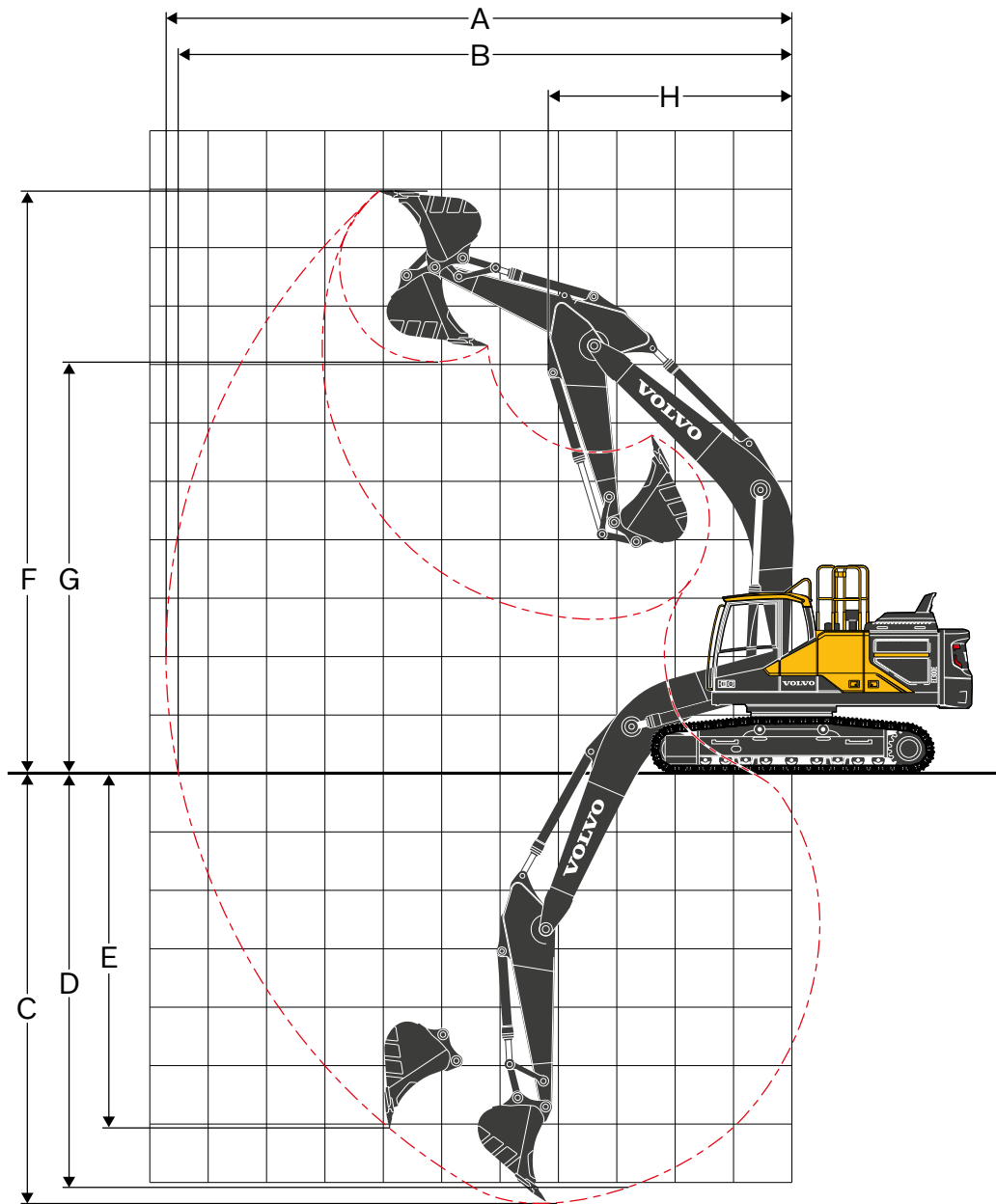

Specifications

MACHINE WEIGHTS AND GROUND PRESSURE

Description	Shoe width	Operating weight	Ground pressure	Overall width	Operating weight	Ground pressure	Overall width
	mm	kg	kPa	mm	kg	kPa	mm
EC300EL Hybrid							
		6.2 m boom (GP), 3.05 m arm (GP), 1 209 kg / 1.32 m³ bucket, 6 200 kg counterweight			6.2 m boom (HD), 3.05 m arm (HD), 1 209 kg / 1.32 m³ bucket, 6 200 kg counterweight		
Triple grouser	600	31 120	60.0	3 190	31 420	60.6	3 190
	600 (HD)	31 340	60.5	3 190	31 630	61.0	3 190
	700	31 710	52.4	3 290	32 000	52.9	3 290
	800	32 070	46.4	3 390	32 360	46.8	3 390
	900	32 430	41.7	3 490	32 720	42.1	3 490
Double grouser	700	31 900	52.8	3 290	32 190	53.2	3 290
EC300ENL Hybrid							
		6.2 m boom (GP), 3.05 m arm (GP), 1 209 kg / 1.32 m³ bucket, 6 200 kg counterweight			6.2 m boom (HD), 3.05 m arm (HD), 1 209 kg / 1.32 m³ bucket, 6 200 kg counterweight		
Triple grouser	600	30 990	59.8	2 990	31 280	60.3	2 990
	600 (HD)	31 200	60.2	2 990	31 500	60.8	2 990
	700	31 570	52.2	3 090	31 870	52.7	3 090
	800	31 940	46.2	3 190	32 230	46.6	3 190
	900	32 300	41.5	3 290	32 590	41.9	3 290
Double grouser	700	31 770	52.5	3 090	32 060	53.0	3 090

BUCKET SELECTION GUIDE

Bucket type		Capacity	Cutting width	Weight	Teeth	EC300EL Hybrid			EC300ENL Hybrid		
						600 mm shoe, 6 200 kg counterweight			600 mm shoe, 6 200 kg counterweight		
						6.2 m GP Boom			6.2 m Boom		
						L	mm	kg	EA	2.55 m	3.05 m
Direct fit bucket	General purpose	550	600	883	3	C	C	C	C	C	C
		660	750	867	3	C	C	C	C	C	C
		770	900	996	4	C	C	C	C	C	C
		950	1 090	1 025	4	C	C	C	C	C	C
		1 140	1 240	1 192	5	C	C	C	C	C	C
		1 320	1 390	1 209	5	C	C	C	C	C	C
		1 450	1 490	1 270	5	C	C	C	C	C	C
		1 510	1 540	1 314	5	C	C	C	C	C	C
		1 760	1 740	1 448	6	C	C	B	C	B	B
	1 930	1 840	1 529	6	C	C	B	C	B	A	
	2 060	1 950	1 590	6	C	B	A	B	A	X	
	Heavy duty	550	600	881	3	D	D	D	D	D	D
		660	750	920	3	D	D	D	D	D	D
		1 140	1 240	1 214	5	D	D	D	D	D	D
		1 270	1 405	1 336	5	D	D	D	D	D	D
		1 320	1 390	1 301	5	D	D	D	D	D	D
		1 510	1 540	1 387	5	D	D	D	D	D	B
		1 690	1 690	1 485	5	D	D	B	D	C	B
1 930		1 840	1 623	6	C	B	A	B	B	A	
Direct fit bucket (UQC interface)		General purpose	550	600	883	3	C	C	C	C	C
	660		750	867	3	C	C	C	C	C	C
	770		900	996	4	C	C	C	C	C	C
	950		1 090	1 025	4	C	C	C	C	C	C
	1 140		1 240	1 192	5	C	C	C	C	C	C
	1 320		1 390	1 209	5	C	C	C	C	C	B
	1 450		1 490	1 270	5	C	C	C	C	C	B
	1 510		1 540	1 314	5	C	C	B	C	B	A
	1 760		1 740	1 448	6	C	B	A	B	A	X
	1 930	1 840	1 529	6	B	B	A	B	A	X	
	2 060	1 950	1 590	6	B	A	X	A	X	X	
	Heavy duty	550	600	881	3	D	D	D	D	D	D
		660	750	920	3	D	D	D	D	D	D
		1 140	1 240	1 214	5	D	D	D	D	D	C
		1 320	1 390	1 301	5	D	D	C	D	D	B
		1 510	1 540	1 387	5	D	D	B	C	B	A
		1 690	1 690	1 485	5	D	B	A	B	A	X
		1 930	1 840	1 623	6	B	A	X	A	X	X

Please consult with your Volvo dealer for the proper match of buckets and attachments to suit the application.

The recommendations are given as a guide only, based on typical operation conditions.

Bucket capacity based on ISO 7451, heaped material with a 1:1 angle of repose.

Maximum material density

A	1 200~1 300 kg/m ³	Coal, Caliche, Shale
B	1 400~1 600 kg/m ³	Wet earth and clay, Limestone, Sandstone
C	1 700~1 800 kg/m ³	Granite, Wet sand, Well blasted rock
D	> 1 900 kg/m ³	Wet mud, Iron ore
X	Not recommended	

Specifications

LIFTING CAPACITY EC300EL Hybrid

Lifting capacity at the arm end without bucket.

For lifting capacity including bucket, simply subtract actual weight of the direct fit bucket or the bucket with quick coupler from the following values.

	Lifting point	1.5 m		3.0 m		4.5 m		6.0 m		7.5 m		9.0 m		Max. reach		m	
		Along UC	Across UC	Along UC	Across UC	Along UC	Across UC	Along UC	Across UC	Along UC	Across UC	Along UC	Across UC	Along UC	Across UC		
Boom : 6.2 m Arm : 2.55 m Shoe : 600 mm CWT : 6 200 kg	7.5 m	kg							*7 740	*7 740					*7 900	7 640	6.5
	6.0 m	kg							*8 080	*8 080	*7 890	6 040			*7 900	5 970	7.6
	4.5 m	kg					*11 410	*11 410	*9 190	8 330	*8 220	5 930			7 940	5 160	8.2
	3.0 m	kg					*14 580	11 950	*10 630	7 930	*8 890	5 740			7 370	4 760	8.5
	1.5 m	kg					*16 750	11 340	*11 900	7 590	8 740	5 570			7 220	4 630	8.5
	0 m	kg					*17 340	11 140	12 030	7 390	8 610	5 450			7 440	4 750	8.3
	-1.5 m	kg			*12 880	*12 880	*16 910	11 150	11 970	7 340	8 590	5 430			8 170	5 190	7.8
	-3.0 m	kg			*21 080	*21 080	*15 540	11 310	*11 740	7 430					9 850	6 200	6.9
	-4.5 m	kg			*16 820	*16 820	*12 520	11 670							*10 110	8 870	5.4
Boom : 6.2 m Arm : 3.05 m Shoe : 600 mm CWT : 6 200 kg	7.5 m	kg													*6 380	*6 380	7.2
	6.0 m	kg									*7 240	6 130			*6 120	5 320	8.1
	4.5 m	kg					*10 280	*10 280	*8 540	8 440	*7 710	5 990			*6 120	4 680	8.7
	3.0 m	kg					*13 480	12 210	*10 050	8 020	*8 470	5 780	*6 600	4 370	*6 330	4 350	9.0
	1.5 m	kg					*16 040	11 470	*11 460	7 640	8 760	5 580	6 670	4 290	6 600	4 240	9.1
	0 m	kg					*17 170	11 140	12 040	7 390	8 600	5 430			6 770	4 330	8.9
	-1.5 m	kg	*7 610	*7 610	*11 750	*11 750	*17 140	11 070	11 920	7 290	8 530	5 370			7 330	4 660	8.4
	-3.0 m	kg	*13 880	*13 880	*19 440	*19 440	*16 140	11 170	11 970	7 330	8 610	5 440			8 560	5 420	7.5
	-4.5 m	kg			*18 990	*18 990	*13 800	11 450	*10 080	7 560					*9 460	7 180	6.2
Boom : 6.2 m Arm : 3.7 m Shoe : 600 mm CWT : 6 200 kg	7.5 m	kg									*6 290	6 220			*4 930	*4 930	8.0
	6.0 m	kg									*6 390	6 170			*4 750	4 660	8.8
	4.5 m	kg							*7 580	*7 580	*6 980	6 010	*6 390	4 450	*4 750	4 150	9.4
	3.0 m	kg					*11 960	*11 960	*9 180	8 110	*7 840	5 790	6 740	4 350	*4 900	3 880	9.6
	1.5 m	kg					*14 940	11 680	*10 770	7 690	*8 730	5 560	6 620	4 230	*5 200	3 780	9.7
	0 m	kg			*6 730	*6 730	*16 680	11 190	*11 960	7 380	8 550	5 380	6 520	4 140	*5 730	3 840	9.5
	-1.5 m	kg	*6 940	*6 940	*10 930	*10 930	*17 190	11 010	11 870	7 220	8 440	5 280	6 480	4 100	6 470	4 100	9.0
	-3.0 m	kg	*11 570	*11 570	*16 550	*16 550	*16 670	11 030	11 840	7 200	8 440	5 280			7 370	4 650	8.3
	-4.5 m	kg	*17 310	*17 310	*21 340	*21 340	*15 000	11 220	*11 150	7 330					*8 820	5 830	7.1
-6.0 m	kg			*15 770	*15 770	*11 150	*11 150							*9 030	*9 030	5.3	
Boom : 6.2 m Arm : 2.55 m Shoe : 800 mm CWT : 6 200 kg	7.5 m	kg							*7 700	*7 700					*7 860	*7 860	6.5
	6.0 m	kg							*8 040	*8 040	*7 840	6 240			*7 850	6 170	7.6
	4.5 m	kg					*11 350	*11 350	*9 140	8 620	*8 160	6 130			*7 990	5 340	8.2
	3.0 m	kg					*14 480	12 350	*10 560	8 190	*8 820	5 940			7 660	4 920	8.5
	1.5 m	kg					*16 620	11 700	*11 810	7 840	9 080	5 750			7 490	4 790	8.5
	0 m	kg					*17 200	11 490	12 490	7 630	8 940	5 630			7 730	4 910	8.3
	-1.5 m	kg			*12 880	*12 880	*16 770	11 490	12 420	7 570	8 920	5 610			8 480	5 360	7.8
	-3.0 m	kg			*20 880	*20 880	*15 400	11 660	*11 630	7 660					*9 770	6 400	6.9
	-4.5 m	kg			*16 640	*16 640	*12 400	12 030							*10 010	9 150	5.4
Boom : 6.2 m Arm : 3.05 m Shoe : 800 mm CWT : 6 200 kg	7.5 m	kg													*6 470	*6 470	7.2
	6.0 m	kg									*7 190	6 360			*6 200	5 510	8.1
	4.5 m	kg					*10 200	*10 200	*8 480	*8 480	*7 660	6 200			*6 200	4 840	8.7
	3.0 m	kg					*13 320	12 550	*9 950	8 270	*8 390	5 970	*6 680	4 520	*6 400	4 500	9.0
	1.5 m	kg					*15 820	11 730	*11 320	7 840	9 080	5 750	6 930	4 420	*6 830	4 380	9.1
	0 m	kg					*16 910	11 370	*12 230	7 570	8 900	5 590			7 030	4 460	8.9
	-1.5 m	kg	*7 690	*7 690	*11 840	*11 840	*16 890	11 300	12 310	7 460	8 830	5 520			7 600	4 810	8.4
	-3.0 m	kg	*13 970	*13 970	*19 530	*19 530	*15 900	11 420	*11 950	7 510	8 920	5 600			8 870	5 580	7.5
	-4.5 m	kg			*18 650	*18 650	*13 580	11 730	*9 940	7 770					*9 330	7 380	6.2
Boom : 6.2 m Arm : 3.7 m Shoe : 800 mm CWT : 6 200 kg	7.5 m	kg									*6 260	*6 260			*4 930	*4 930	8.0
	6.0 m	kg									*6 350	*6 350			*4 750	*4 750	8.8
	4.5 m	kg							*7 540	*7 540	*6 940	6 230	*6 390	4 610	*4 750	4 300	9.4
	3.0 m	kg					*11 890	*11 890	*9 120	8 390	*7 780	5 990	7 020	4 500	*4 900	4 010	9.6
	1.5 m	kg					*14 830	12 070	*10 690	7 950	*8 670	5 760	6 880	4 380	*5 200	3 910	9.7
	0 m	kg			*6 730	*6 730	*16 550	11 550	*11 860	7 630	8 890	5 570	6 780	4 280	*5 730	3 980	9.5
	-1.5 m	kg	*6 940	*6 940	*10 930	*10 930	*17 040	11 360	12 320	7 460	8 770	5 460	*6 710	4 240	*6 590	4 240	9.0
	-3.0 m	kg	*11 570	*11 570	*16 550	*16 550	*16 530	11 380	*12 260	7 430	8 760	5 450			7 660	4 810	8.3
	-4.5 m	kg	*17 310	*17 310	*21 140	*21 140	*14 860	11 580	*11 040	7 560					*8 730	6 030	7.1
-6.0 m	kg			*15 590	*15 590	*11 030	*11 030							*8 930	*8 930	5.3	

Notes: 1. Machine in "Fine Mode-F" (Power Boost) for lifting capacities. 2. The above loads are in compliance with SAE J1097 and ISO 10567 Hydraulic Excavator Lifting Capacity Standards. 3. Rated loads do not exceed 87% of hydraulic lifting capacity or 75% of tipping load. 4. Rated loads marked with an asterisk (*) are limited by hydraulic capacity rather than tipping load.

LIFTING CAPACITY EC300ENL Hybrid

Lifting capacity at the arm end without bucket.

For lifting capacity including bucket, simply subtract actual weight of the direct fit bucket or the bucket with quick coupler from the following values.

	Lifting point	1.5 m		3.0 m		4.5 m		6.0 m		7.5 m		9.0 m		Max. reach		m
		Along UC	Across UC	Along UC	Across UC	Along UC	Across UC	Along UC	Across UC	Along UC	Across UC	Along UC	Across UC	Along UC	Across UC	
Boom: 6.2 m Arm: 2.55 m Shoe: 600 mm CWT: 6 200 kg	7.5 m kg							*7 740	*7 740					*7 900	7 050	6.5
	6.0 m kg							*8 080	7 980	*7 890	5 560			*7 900	5 500	7.6
	4.5 m kg					*11 410	*11 410	*9 190	7 660	*8 220	5 460			7 900	4 750	8.2
	3.0 m kg					*14 580	10 850	*10 630	7 260	*8 890	5 280			7 330	4 370	8.5
	1.5 m kg					*16 750	10 260	*11 900	6 930	8 700	5 100			7 180	4 250	8.5
	0 m kg					*17 340	10 060	11 970	6 740	8 570	4 990			7 400	4 350	8.3
	-1.5 m kg			*12 880	*12 880	*16 910	10 070	11 910	6 690	8 550	4 970			8 130	4 750	7.8
	-3.0 m kg			*21 080	20 130	*15 540	10 230	*11 740	6 780					9 800	5 670	6.9
	-4.5 m kg			*16 820	*16 820	*12 520	10 570							*10 110	8 090	5.4
Boom: 6.2 m Arm: 3.05 m Shoe: 600 mm CWT: 6 200 kg	7.5 m kg													*6 380	6 060	7.2
	6.0 m kg									*7 240	5 660			*6 120	4 900	8.1
	4.5 m kg					*10 280	*10 280	*8 540	7 760	*7 710	5 510			*6 120	4 300	8.7
	3.0 m kg					*13 480	11 100	*10 050	7 350	*8 470	5 310	*6 600	4 010	*6 330	3 990	9.0
	1.5 m kg					*16 040	10 380	*11 460	6 980	8 710	5 110	6 630	3 930	6 560	3 880	9.1
	0 m kg					*17 170	10 060	11 980	6 730	8 550	4 970			6 730	3 960	8.9
	-1.5 m kg	*7 610	*7 610	*11 750	*11 750	*17 140	10 000	11 860	6 640	8 490	4 910			7 290	4 270	8.4
	-3.0 m kg	*13 880	*13 880	*19 440	*19 440	*16 140	10 100	11 910	6 680	8 570	4 980			8 520	4 960	7.5
	-4.5 m kg			*18 990	*18 990	*13 800	10 370	*10 080	6 900					*9 460	6 560	6.2
Boom: 6.2 m Arm: 3.7 m Shoe: 600 mm CWT: 6 200 kg	7.5 m kg									*6 290	5 740			*4 930	*4 930	8.0
	6.0 m kg									*6 390	5 690			*4 750	4 280	8.8
	4.5 m kg							*7 580	*7 580	*6 980	5 530	*6 390	4 080	*4 750	3 800	9.4
	3.0 m kg					*11 960	11 400	*9 180	7 430	*7 840	5 320	6 710	3 980	*4 900	3 550	9.6
	1.5 m kg					*14 940	10 580	*10 770	7 030	8 710	5 090	6 580	3 870	*5 200	3 450	9.7
	0 m kg			*6 730	*6 730	*16 680	10 110	*11 960	6 730	8 510	4 920	6 480	3 780	*5 730	3 510	9.5
	-1.5 m kg	*6 940	*6 940	*10 930	*10 930	*17 190	9 940	11 800	6 570	8 390	4 820	6 450	3 750	6 440	3 740	9.0
	-3.0 m kg	*11 570	*11 570	*16 550	*16 550	*16 670	9 960	11 780	6 550	8 390	4 810			7 330	4 250	8.3
	-4.5 m kg	*17 310	*17 310	*21 340	19 960	*15 000	10 140	*11 150	6 670					*8 820	5 330	7.1
-6.0 m kg			*15 770	*15 770	*11 150	10 570							*9 030	8 370	5.3	

Notes: 1. Machine in "Fine Mode-F" (Power Boost) for lifting capacities. 2. The above loads are in compliance with SAE J1097 and ISO 10567 Hydraulic Excavator Lifting Capacity Standards. 3. Rated loads do not exceed 87% of hydraulic lifting capacity or 75% of tipping load. 4. Rated loads marked with an asterisk (*) are limited by hydraulic capacity rather than tipping load.

Equipment

STANDARD EQUIPMENT

Engine

Turbocharged, 4 stroke diesel engine with water cooling, direct injection and charged air cooler that meets EU Stage V requirements

Air filter with indicator

Air intake heater

Cyclone pre-cleaner

Electric engine shut-off

Fuel filter and water separator

Fuel filler pump: 50 l/min, with automatic shut-off

Alternator, 80 A

Hybrid

Accumulator, 20 L

Boom regeneration valves

Assist motor

Main pump with PTO

Electric / Electronic control system

Advanced mode control system

Self-diagnostic system

Machine status indication

Engine speed sensing power control

Automatic idling system

Onetouch power boost

Safety stop/start function

Adjustable LCD color monitor

Master electrical disconnect switch

Engine restart prevention circuit

High-capacity LED lights:

- Frame-mounted 2

- Boom-mounted 1

Batteries, 2 x 12 V / 170 A

Start motor, 24 V / 5.5 kW

Frame

Access way with handrail

Tool storage area

Punched metal anti-slip plates

Counterweight: 6 200 kg

Undercarriage

Undercover (heavy-duty)

Hydraulic track adjusters

Greased and sealed track link

Track Guard

Hydraulic system

Boom up swing priority function

Boom travel priority function (Creep)

Boom down speed control

Hose rupture valve: boom & arm

Overload warning device

Automatic sensing hydraulic system

- Summation system

- Boom priority

- Arm priority

- Swing priority

ECO mode fuel saving technology

Boom, arm and bucket regeneration valves

Swing anti-rebound valves

Boom and arm holding valves

Multi-stage filtering system

Cylinder cushioning

Cylinder contamination seals

Auxiliary hydraulic valve

Automatic two-speed travel motors

Hydraulic oil, longlife oil 46

STANDARD EQUIPMENT

Cab and interior

ROPS (ISO 12117-2) certified cab

Silicon oil and rubber mounts with spring

Travel pedals and hand levers

Adjustable operator seat and joystick control console

Proportional joysticks with 3 switches

Heater & air-conditioner, automatic

Flexible antenna

Radio with MP3 & USB Jack with bluetooth

Hydraulic safety lock lever

Cab, all-weather sound suppressed, includes:

- Cup holders

- Door locks

- Tinted glass

- Floor mat

- Horn

- Large storage area

- Pull-up type front window

- Removable lower windshield

- Seat belt

- Safety glass

- Sun screens, front, roof, rear

- Rain shield

- Windshield wiper with intermittent feature

Rear view camera

Side view camera

Master key

Track shoes

600 mm with triple grousers

Digging equipment

Boom: 6.2 m monoblock

Arm: 3.05 m

Manual centralized lubrication

OPTIONAL EQUIPMENT

Engine

Block heater: 120 V, 240 V

Oil bath pre-cleaner

Diesel coolant heater, 10 kW

Water separator with heater

Auto engine shutdown

Reversible fan

Delayed engine shutdown

Electric

Extra work lights (Halogen or LED):

- Cab-mounted 3

- Boom-mounted 1

- Counterweight-mounted 1

Green light beacon

Travel alarm

Anti-theft system

Rotating warning beacon

Smart connect for tilt rotator

Tilt rotator 3rd gen

Dig assist, smart connect

OPTIONAL EQUIPMENT

Undercarriage

Full track guard

Track shoes

700/800/900 mm with triple grousers

600 mm HD with triple grousers

600/700 mm with double grousers

High walker undercarriage

Hydraulic system

CDC, Comfort Driving Control

Boom float function with HRV

Boom float function without HRV

Attachment management system (up to 32 programmable memories)

- Variable flow and pressure pre-setting

Hammer & shear, 1 and 2 pump flow

Additional return filter

Hydraulic piping:

- Slope & rotator

- Grapple

- Oil leak (drain) line

Quick coupler piping

Volvo hydraulic quick coupler S2

Volvo hydraulic quick coupler U30

Volvo hydraulic quick coupler S70

Volvo hydraulic quick coupler SQ70 55

Volvo hydraulic quick coupler SQ70

Hydraulic oil, biodegradable 46

Hydraulic oil, longlife oil 32

Hydraulic oil, longlife oil 68

Fuel tank-fast fuel fill prep

Straight travel pedal

OPTIONAL EQUIPMENT

Cab and interior

Fabric seat with heater

Fabric seat with heater and air suspension

Deluxe seat

High-strength one piece front windshield (P5A)

Opening top hatch

Falling object guard, FOG (fixed type or hinge type)

Frame-mounted

Cab-mounted

Cab-mounted falling object protective structure (FOPS)

Volvo smart view

Smoker kit (ashtray and lighter)

Safety net for front window

Lower wiper with intermittent control

Anti-vandalism kit

Specific key

Cleaning air gun

Digging equipment

Arm: 2.55 m HD, 3.05 m HD, 3.7 m

Linkage with lifting eye

Machine controls

Dig Assist

Volvo Active Control (Semi-autonomous)

Please refer to separate Brochure for more details

Service

Tool kit, daily maintenance

Tool kit, full scale

SELECTION OF VOLVO OPTIONAL EQUIPMENT

Swing out FOG**TiltRotator****Volvo Smart View**

Not all products are available in all markets. Under our policy of continuous improvement, we reserve the right to change specifications and design without prior notice. The illustrations do not necessarily show the standard version of the machine.

VOLVO

Volvo Construction Equipment

volvoce.com