

Volvo Construction Equipment
Building Tomorrow



EC350E HYBRID

Volvo Excavators



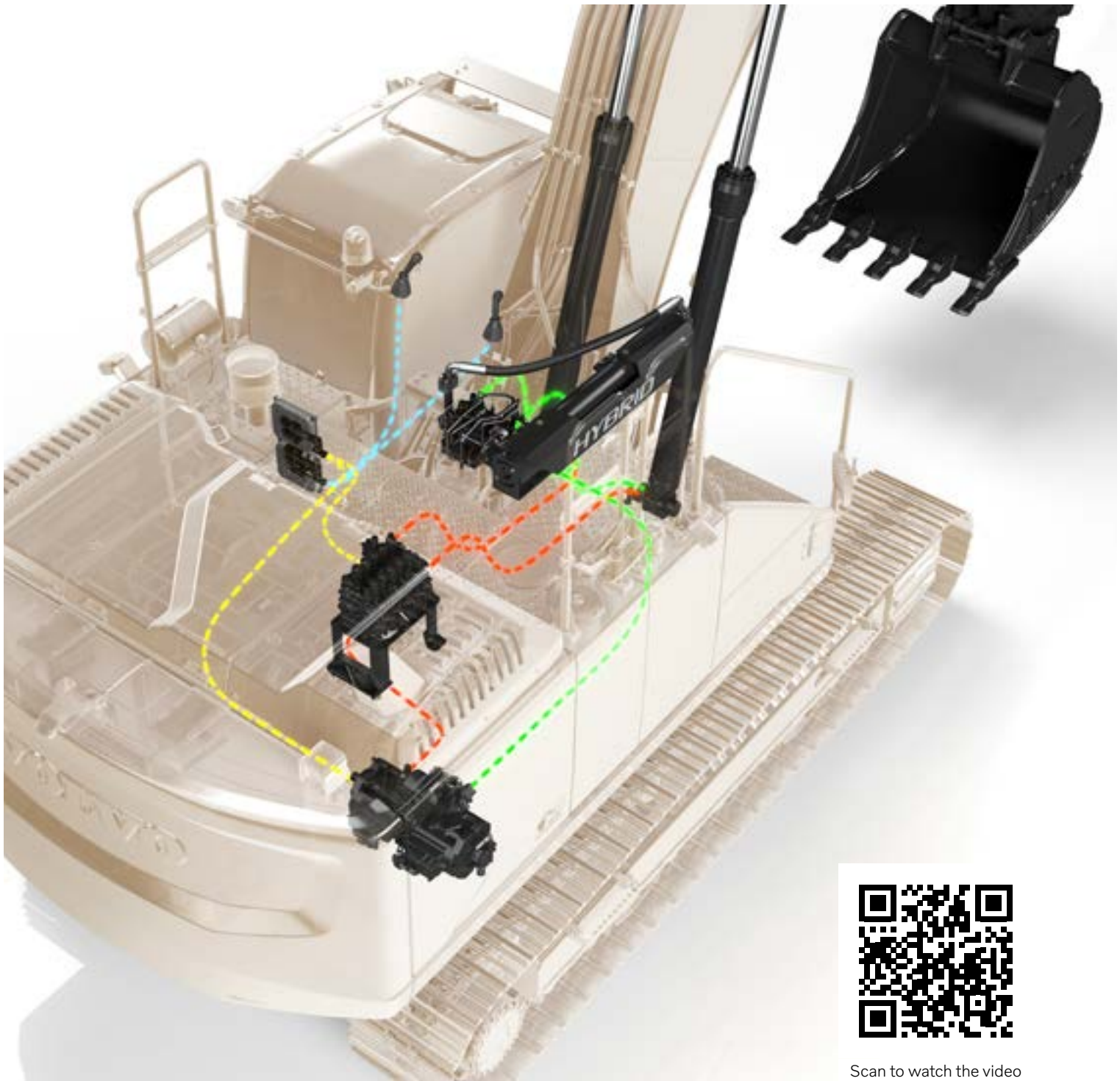

Scan to watch the video

Simple solution, big savings

Introducing the new EC350E Hybrid. Featuring unique hydraulic hybrid Volvo technology, the excavator utilizes the boom down motion to charge the accumulator, with the stored energy used to drive the assist motor, which powers the engine system.

The result is up to 17%* increase in fuel efficiency while delivering all the power and performance you would expect from a conventional EC350E.

*Efficiency and savings may vary based on operator, application and conditions.



17%
greater fuel
efficiency*



15%
lower fuel
consumption*

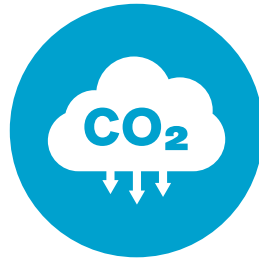

15%
reduction in
CO₂ emissions*



100%
Volvo engineered
hydraulic hybrid

Simply reliable

The uncomplicated and reliable hybrid solution is easy to maintain and consists of just a handful of add-on components, meaning no disruption or complication to how the high performing EC350E is engineered.



Cleaner and greener

The EC350E Hybrid reduces CO₂ emissions by up to 15%* making it a more environmentally respectful choice, especially when working in built-up areas.

Rapid payback

When working in dig and dump applications, the EC350E Hybrid is a straightforward solution with fast payback. Save fuel, lower emissions and boost the profitability of your operation.

EC350E Hybrid in detail

Engine

The next-generation Volvo diesel engine uses Volvo Advanced Combustion Technology (V-ACT) to deliver lower emissions, superior performance and fuel efficiency. The engine uses precise, highpressure fuel injectors, turbo charger and intercooler, and electronic engine controls to optimize machine performance.

Engine	Volvo	D8M
Max power at	r/min	1 600
Net, ISO 9249/SAE J1349	kW	219
	hp	298
Gross, ISO 14396/SAE J1995	kW	220
	hp	299
Max torque	Nm	1 400
at engine speed	r/min	1 400
No. of cylinders		6
Displacement	l	7.7
Bore	mm	110
Stroke	mm	135

Hybrid

The uncomplicated and reliable hybrid solution, Volvo's novel hydraulic hybrid harvests 'free' energy generated by the down motion of the excavator's boom and uses it to supercharge the engine system. The powerful and regular boom-down motions charge the 26 litre hydraulic accumulator (6.9 gallon), which then delivers energy to drive the hydraulic assist motor that helps to power the engine system. There are the same levels of controllability and performance as the standard EC350E, including the ability to work in ECO mode and Hybrid mode simultaneously.

Accumulator

No. of accumulator		1
Displacement	l	26

Electrical System

High-capacity electrical system that is well protected. Waterproof double-lock harness plugs are used to secure corrosion-free connections. The main relays and solenoid valves are shielded to prevent damage. The master switch is standard.

Voltage	V	24
Batteries	V	2 x 12
Battery capacity	Ah	170
Alternator	V/A	28/120
Start motor	V - kW	24 - 5.5

Undercarriage

The undercarriage has a robust X-shaped frame. Greased and sealed track chains are standard.

Track shoes		2 x 48
Link pitch	mm	215.9
Shoe width, triple grouser	mm	600 / 700 / 800 / 900
Shoe width, triple grouser (HD)	mm	600
Shoe width, double grouser	mm	600
Bottom rollers		2 x 8
Top rollers		2 x 2

Cab

The operator's cab has easy access via a wide door opening. The cab is supported on hydraulic dampening mounts to reduce shock and vibration levels. These along with sound absorbing lining provide low noise levels. The cab has excellent all-round visibility. The front windshield can easily slide up into the ceiling, and the lower front glass can be removed and stored in the side door.

Integrated air-conditioning and heating system: The pressurized and filtered cab air is supplied by an automatically-controlled fan. The air is distributed throughout the cab from 14 vents.

Ergonomic operator's seat: The adjustable seat and joystick console move independently to accommodate the operator. The seat has nine different adjustments plus a seat belt for the operator's comfort and safety. Refrigerant of the type R134a is used when this machine is equipped with air conditioning. Contains fluorinated greenhouse gas R134a, Global Warming Potential 1.430 t CO₂-eq.

Swing system

The swing system uses an axial piston motors, driving a planetary gearbox for maximum torque. An automatic holding brake and anti-rebound valve are standard.

Max. slew speed	r/min	10.3
Max. slew torque	kNm	126.2

Travel System

Each track is powered by an automatic two-speed shift travel motor. The track brakes are multi-disc, spring-applied and hydraulic released. The travel motor, brake and planetary gears are well protected within the track frame.

Max. drawbar pull	kN	261
Max. travel speed (low)	km/h	3.3
Max. travel speed (high)	km/h	5.1
Gradeability	°	35

Sound Level

Sound pressure level in cab according to ISO 6396

L _{pA}	dB	71
-----------------	----	----

External sound level according to ISO 6395 and EU Noise Directive 2000/14/EC

L _{WA}	dB	105
-----------------	----	-----

Hydraulic system

The hydraulic system, also known as the "Automatic Sensing Work Mode," is designed for high-productivity, high-digging capacity, high-maneuvering precision and excellent fuel economy. The summation system, boom, arm and swing priority along with boom, arm and bucket regeneration provides optimum performance.

The following important functions are included in the system:

Summation system: Combines the flow of both hydraulic pumps to ensure quick cycle times and high productivity.

Boom priority: Gives priority to the boom operation for faster raising when loading or performing deep excavations.

Arm priority: Gives priority to the arm operation for faster cycle times in leveling and for increased bucket filling when digging.

Swing priority: Gives priority to swing functions for faster simultaneous operations.

Regeneration system: Prevents cavitation and provides flow to other movements during simultaneous operations for maximum productivity.

Power boost: All digging and lifting forces are increased.

Holding valves: Boom and arm holding valves prevent the digging equipment from creeping.

Main pump, Type 2 x Variable displacement axial piston pumps

Maximum flow	l/min	2 x 288
--------------	-------	---------

Pilot pump, Type Gear pump

Maximum flow	l/min	20
--------------	-------	----

Relief value setting pressure

Implement	MPa	33.3 / 36.3
Travel circuit	MPa	33.3
Slew circuit	MPa	27.9
Pilot circuit	MPa	3.9

Hydraulic Motors

Travel: Variable displacement axial piston motor with mechanical brake.

Slew: Fixed displacement piston motor with mechanical brake.

Hydraulic Cylinders

Mono boom		2
Bore x Stroke	ø x mm	150 x 1 530
Arm		1
Bore x Stroke	ø x mm	170 x 1 700
Bucket		1
Bore x Stroke	ø x mm	140 x 1 285

Service Refill

Fuel tank	l	580
DEF/AdBlue® tank	l	50
Hydraulic system, total	l	465
Hydraulic tank	l	215
Engine oil	l	30
Engine coolant	l	44
Slew reduction unit	l	6
Travel reduction unit	l	2 x 6.8

Specifications

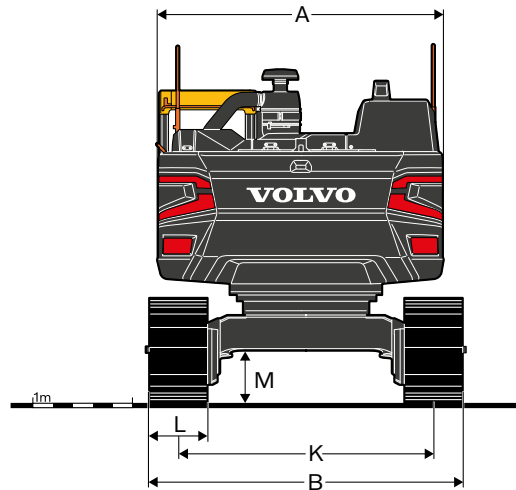
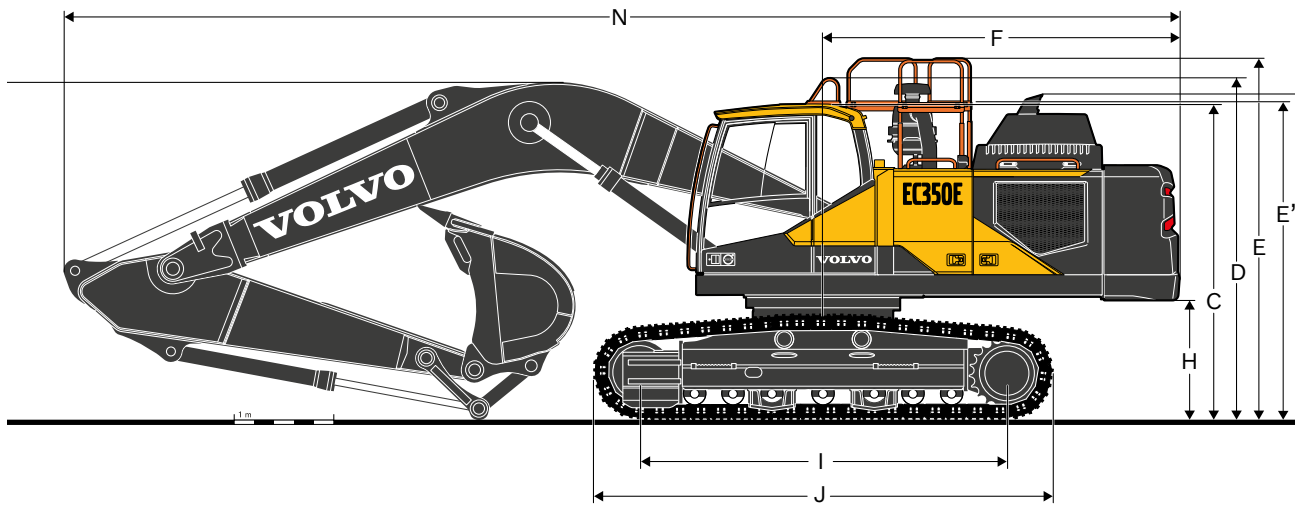

DIMENSIONS

Description	Unit	EC350EL Hybrid			EC350ENL Hybrid		
		2.6 HD	3.2 HD	3.9 GP	2.6 HD	3.2 GP	3.9 GP
Boom	m	6.45			6.45		
Arm	m	2.6 HD	3.2 HD	3.9 GP	2.6 HD	3.2 GP	3.9 GP
A. Overall width of upper structure	mm	2 890	2 890	2 890	2 890	2 890	2 890
B. Overall width	mm	3 190	3 190	3 190	2 990	2 990	2 990
C. Overall height of cab	mm	3 175	3 175	3 175	3 175	3 175	3 175
D. Overall height of handrail (Unfolded)	mm	3 440	3 440	3 440	3 440	3 440	3 440
E. Overall height of guardrail (Unfolded)	mm	3 650	3 650	3 650	3 650	3 650	3 650
E'. Overall height of handrail&guardrail (Folded)	mm	3 165	3 165	3 165	3 165	3 165	3 165
F. Tail swing radius	mm	3 600	3 600	3 600	3 600	3 600	3 600
G. Overall height of diffuser	mm	3 265	3 265	3 265	3 265	3 265	3 265
H. Counterweight clearance *	mm	1 170	1 170	1 170	1 170	1 170	1 170
I. Tumbler length	mm	4 020	4 020	4 020	4 020	4 020	4 020
J. Track length	mm	4 945	4 945	4 945	4 945	4 945	4 945
K. Track gauge	mm	2 590	2 590	2 590	2 390	2 390	2 390
L. Shoe width	mm	600	600	600	600	600	600
M. Min. ground clearance *	mm	500	500	500	500	500	500
N. Overall length	mm	11 295	11 200	11 245	11 295	11 210	11 245
O. Overall height of boom	mm	3 565	3 380	3 575	3 565	3 380	3 575

* Without shoe grouser

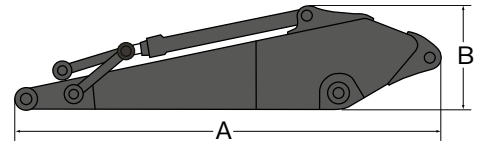
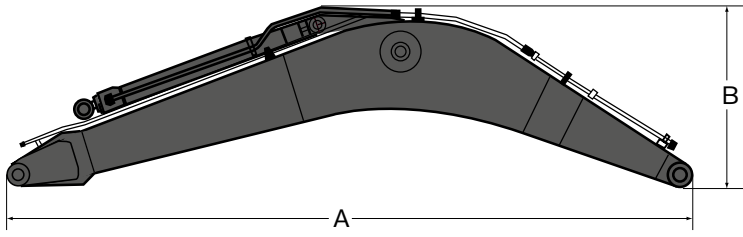

DIMENSIONS

Description	Unit	EC350E Hybrid		Description	Unit	EC350E Hybrid			
		6.45 GP	6.45 HD			2.6 HD	3.2 GP	3.2 HD	3.9 GP
Boom	m			Arm	m				
A. Length	mm	6 710	6 710	A. Length	mm	3 670	4 350	4 345	5 045
B. Height	mm	1 845	1 845	B. Height	mm	1 135	1 060	1 080	1 080
Width	mm	815	815	Width	mm	570	570	570	570
Weight	kg	3 205	3 490	Weight	kg	1 940	1 920	2 020	2 140

* Includes cylinder, piping and pin, excludes boom cyl. Pin

* Includes cylinder, linkage and pin

Specifications

WORKING RANGES						
Description		Unit	EC350E Hybrid			
Boom		m	6.45			
Arm		m	2.6	3.2	3.9	
A. Max. digging reach		mm	10 600	11 120	11 760	
B. Max. digging reach on ground		mm	10 380	10 910	11 560	
C. Max. digging depth		mm	6 890	7 490	8 190	
D. Max. digging depth (2.44 m level)		mm	6 690	7 310	8 040	
E. Max. cutting height		mm	10 170	10 330	10 600	
F. Max. dumping height		mm	7 050	7 240	7 510	
G. Max. vertical wall digging depth		mm	4 790	5 220	5 800	
H. Min. front swing radius		mm	4 320	4 290	4 240	
DIGGING FORCES WITH DIRECT FIT BUCKET						
Bucket radius		mm	1 746	1 746	1 746	
Breakout force	Normal	SAE J1179	kN	176	177	176
	Power boost		kN	192	192	192
	Normal	ISO 6015	kN	201	201	201
	Power boost		kN	218	219	219
Tearout force	Normal	SAE J1179	kN	187	156	136
	Power boost		kN	203	169	148
	Normal	ISO 6015	kN	192	160	139
	Power boost		kN	209	174	151
Rotation angle, bucket			°	178		

MACHINE WITH MONO BOOM

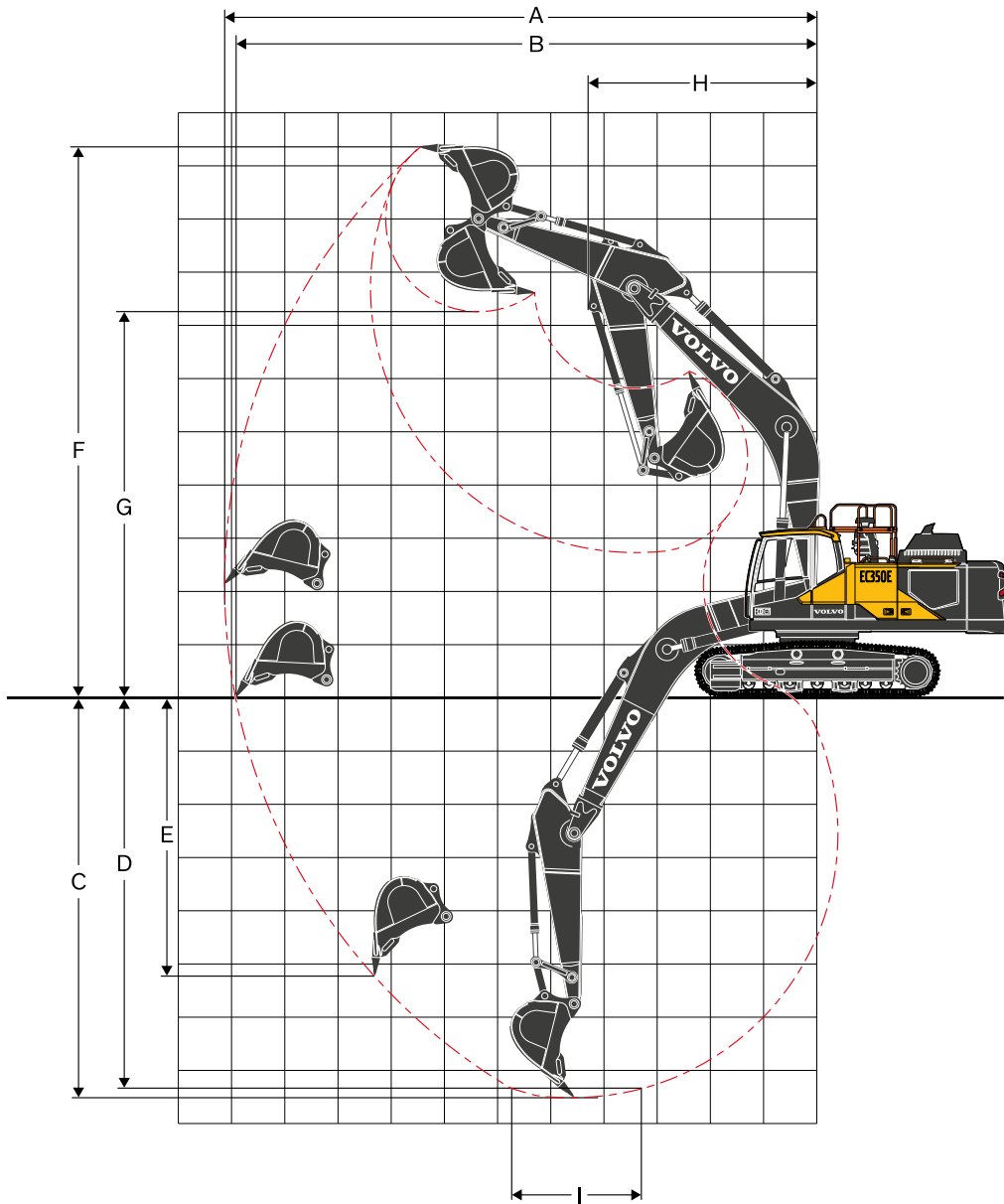

Specifications

GROUND PRESSURE

Description	Shoe width	Operating weight	Ground pressure	Overall width	Operating weight	Ground pressure	Overall width	Operating weight	Ground pressure	Overall width
	mm	kg	kPa	mm	kg	kPa	mm	kg	kPa	mm
EC350EL Hybrid										
		6.45 m boom (HD), 2.6 m arm (HD), 1 730 kg bucket, 7 000 kg counterweight			6.45 m boom (HD), 3.2 m arm (HD), 1 730 kg bucket, 7 000 kg counterweight			6.45 m boom (HD), 3.9 m arm (GP), 1 730 kg bucket, 7 000 kg counterweight		
Triple grouser	600	36 740	70.5	3 190	36 820	70.6	3 190	36 890	70.8	3 190
	600 (HD)	36 780	70.6	3 190	36 860	70.7	3 190	36 930	70.8	3 190
	700	37 360	61.4	3 290	37 450	61.6	3 290	37 510	61.7	3 290
	800	37 760	54.3	3 390	37 840	54.4	3 390	37 910	54.5	3 390
	900	38 150	48.8	3 490	38 230	48.9	3 490	38 290	49.0	3 490
Double grouser	600	37 440	71.8	3 190	37 520	72.0	3 190	37 580	72.1	3 190
EC350ENL Hybrid										
		6.45 m boom (HD), 2.6 m arm (HD), 1 675 kg bucket, 7 000 kg counterweight			6.45 m boom (HD), 3.2 m arm (HD), 1 675 kg bucket, 7 000 kg counterweight			6.45 m boom (HD), 3.9 m arm (GP), 1 675 kg bucket, 7 000 kg counterweight		
Triple grouser	600	36 540	70.1	2 990	36 620	70.2	2 990	36 740	70.5	2 990
	600 (HD)	36 580	70.2	2 990	36 670	70.3	2 990	36 790	70.6	2 990
	700	37 170	61.1	3 090	37 250	61.2	3 090	37 370	61.4	3 090
	800	37 560	54.0	3 190	37 640	54.2	3 190	37 760	54.3	3 190
	900	37 950	48.5	3 290	38 030	48.6	3 290	38 150	48.8	3 290
Double grouser	600	37 240	71.4	2 990	37 320	71.6	2 990	37 440	71.8	2 990
		6.45 m boom (GP), 2.6 m arm (HD), 1 675 kg bucket, 7 000 kg counterweight			6.45 m boom (GP), 3.2 m arm (GP), 1 675 kg bucket, 7 000 kg counterweight			6.45 m boom (GP), 3.9 m arm (GP), 1 675 kg bucket, 7 000 kg counterweight		
Triple grouser	600	36 260	69.6	2 990	36 240	69.5	2 990	36 460	69.9	2 990
	600 (HD)	36 300	69.6	2 990	36 280	69.6	2 990	36 500	70.0	2 990
	700	36 880	60.6	3 090	36 860	60.6	3 090	37 080	61.0	3 090
	800	37 280	53.6	3 190	37 260	53.6	3 190	37 480	53.9	3 190
	900	37 660	48.2	3 290	37 640	48.1	3 290	37 870	48.4	3 290
Double grouser	600	36 950	70.9	2 990	36 930	70.8	2 990	37 160	71.3	2 990

BUCKET SELECTION GUIDE

Bucket type				Capacity	Cutting width	Weight	Teeth	EC350EL Hybrid			EC350ENL Hybrid				
								600 mm shoe, 7 000 kg counterweight							
								6.45 m HD Boom			6.45 m GP Boom				
								L	mm	kg	EA	2.6 m Arm	3.2 m Arm	3.9 m Arm	2.6 m Arm
Direct Fit Buckets	Without Quick Coupler	V4	GP	870	750	1 082	3	C	C	C	C	C	C		
				1 000	900	1 281	4	C	C	C	C	C	C		
				1 420	1 200	1 514	5	C	C	C	C	C	C		
				1 670	1 350	1 629	5	C	C	C	C	C	B		
				1 920	1 500	1 769	5	C	C	B	C	B	A		
			2 330	1 750	1 967	5	B	B	A	B	A	X			
			HD	870	750	1 352	3	D	D	D	D	D	D		
				1 000	900	1 425	4	D	D	D	D	D	D		
				1 420	1 200	1 679	4	D	D	D	D	D	D		
				1 420	1 200	1 699	5	D	D	D	D	D	D		
		1 670		1 380	1 821	5	D	D	C	D	C	B			
		Quick Coupler Buckets	U type quick coupler	V4	GP	870	750	1 082	3	C	C	C	C	C	C
						1 000	900	1 281	4	C	C	C	C	C	C
						1 420	1 200	1 514	5	C	C	C	C	C	B
1 670	1 350					1 629	5	C	C	B	C	B	A		
1 920	1 500					1 769	5	C	B	A	B	A	X		
2 330	1 750				1 967	5	A	A	X	A	X	X			
HD	870				750	1 352	3	D	D	D	D	D	D		
	1 000				900	1 425	4	D	D	D	D	D	D		
	1 420				1 200	1 699	5	D	D	B	D	C	A		
	1 670				1 380	1 821	5	D	B	A	B	B	A		
	1 920			1 500	1 970	5	B	A	X	A	A	X			
S-quick coupler	V4			GP	1 000	900	1 328	4	C	C	C	C	C	C	
					1 180	1 050	1 419	4	C	C	C	C	C	C	
					1 420	1 200	1 571	5	C	C	C	C	C	B	
		1 670	1 350		1 686	5	C	C	B	C	B	A			
		1 920	1 500		1 809	5	C	B	A	B	A	A			
		2 330	1 750	1 918	5	B	A	X	A	X	X				
		HD	1 000	900	1 400	4	D	D	D	D	D	D			
			1 420	1 200	1 655	5	D	D	C	D	D	B			
			1 670	1 350	1 782	5	D	C	B	C	B	A			
			1 920	1 500	1 928	5	C	B	A	B	A	X			
2 330	1 750		2 126	5	A	A	X	A	X	X					

Please consult with your Volvo dealer for the proper match of buckets and attachments to suit the application.

(In case of using bigger bucket than regional standard MRS, consultation with R&D is highly recommended)

The recommendations are given as a guide only, based on typical operation conditions.

Bucket capacity based on ISO 7451, heaped material with a 1:1 angle of repose.

Maximum load : Payload, bucket and additional tools such as quick coupler, rotator,...

Maximum material density

A	1 200~1 300 kg/m ³	Coal, Caliche, Shale
B	1 400~1 600 kg/m ³	Wet earth and clay, Limestone, Sandstone
C	1 700~1 800 kg/m ³	Granite, Wet sand, Well blasted rock
D	> 1 900 kg/m ³	Wet mud, Iron ore
X	Not recommended	

LIFTING CAPACITY EC350ENL Hybrid

Lifting capacity at the arm end without bucket.

For lifting capacity including bucket, simply subtract actual weight of the direct fit bucket or the bucket with quick coupler from the following values.

Lifting point		1.5 m		3.0 m		4.5 m		6.0 m		7.5 m		9.0 m		Max. reach			
		Along UC	Across UC	Along UC	Across UC	Along UC	Across UC	Along UC	Across UC	Along UC	Across UC	Along UC	Across UC	Along UC	Across UC	m	
Boom : 6.45 m GP Arm : 2.6 m HD Shoe : 600 mm CWT : 7 000 kg	7.5 m	kg												*9 220	7 500	7.0	
	6.0 m	kg							*9 760	9 560	*9 150	6 660			*9 150	6 000	8.0
	4.5 m	kg					*14 260	13 930	*11 130	9 080	*9 690	6 470			8 680	5 230	8.5
	3.0 m	kg							*12 770	8 540	10 420	6 200			8 110	4 850	8.8
	1.5 m	kg							*14 100	8 110	10 150	5 970			7 960	4 720	8.8
	0 m	kg							*20 130	11 810	13 980	7 870	9 990	5 820	8 220	4 850	8.6
	-1.5 m	kg			*14 400	*14 400	*19 390	11 860	13 920	7 820	9 960	5 790			9 000	5 290	8.1
	-3.0 m	kg			*23 280	*23 280	*17 640	12 070	*13 490	7 950					*10 720	6 280	7.2
	-4.5 m	kg			*18 460	*18 460	*14 170	12 510							*10 650	8 740	5.8
Boom : 6.45 m GP Arm : 3.2 m GP Shoe : 600 mm CWT : 7 000 kg	7.5 m	kg								*8 290	6 860			*7 380	6 590	7.7	
	6.0 m	kg								*8 410	6 800			*7 180	5 430	8.5	
	4.5 m	kg					*12 790	*12 790	*10 320	9 300	*9 090	6 580	*7 960	4 870	*7 250	4 800	9.1
	3.0 m	kg					*16 480	13 220	*12 090	8 750	*10 010	6 310	7 910	4 750	7 450	4 470	9.3
	1.5 m	kg					*19 190	12 350	*13 660	8 280	10 240	6 050	7 770	4 620	7 320	4 350	9.4
	0 m	kg					*20 220	11 990	14 100	7 980	10 030	5 860	7 670	4 530	7 520	4 440	9.1
	-1.5 m	kg			*14 520	*14 520	*20 000	11 920	13 960	7 860	9 940	5 780			8 120	4 780	8.6
	-3.0 m	kg	*16 920	*16 920	*22 970	*22 970	*18 720	12 040	14 010	7 910	10 000	5 840			9 430	5 530	7.8
	-4.5 m	kg			*21 710	*21 710	*16 020	12 360	*11 980	8 140					*10 480	7 220	6.6
Boom : 6.45 m GP Arm : 3.9 m GP Shoe : 600 mm CWT : 7 000 kg	9.0 m	kg												*6 290	*6 290	7.3	
	7.5 m	kg								*7 200	7 070			*5 870	5 690	8.4	
	6.0 m	kg								*7 510	6 950	*7 020	5 040	*5 730	4 790	9.2	
	4.5 m	kg							*9 190	*9 190	*8 280	6 690	*7 800	4 940	*5 780	4 280	9.7
	3.0 m	kg					*14 560	13 590	*11 020	8 890	*9 280	6 360	7 950	4 770	*5 990	4 000	10.0
	1.5 m	kg					*17 770	12 460	*12 780	8 310	10 260	6 040	7 760	4 590	*6 390	3 890	10.0
	0 m	kg			*9 000	*9 000	*19 530	11 850	14 040	7 910	9 970	5 790	7 610	4 460	6 720	3 940	9.8
	-1.5 m	kg	*9 190	*9 190	*13 740	*13 740	*19 950	11 630	13 790	7 700	9 810	5 650	7 540	4 390	7 170	4 190	9.3
	-3.0 m	kg	*14 330	*14 330	*19 870	*19 870	*19 260	11 660	13 760	7 670	9 800	5 640			8 100	4 730	8.6
Boom : 6.45 m GP Arm : 2.6 m HD Shoe : 700 mm CWT : 7 000 kg	9.0 m	kg												*6 290	*6 290	7.3	
	7.5 m	kg								*7 200	7 170			*5 870	5 770	8.5	
	6.0 m	kg								*7 520	7 040	*7 030	5 120	*5 730	4 870	9.2	
	4.5 m	kg							*9 190	*9 190	*8 280	6 780	*7 800	5 010	*5 780	4 350	9.7
	3.0 m	kg					*14 580	13 770	*11 030	9 010	*9 280	6 460	8 080	4 850	*6 000	4 070	10.0
	1.5 m	kg					*17 780	12 650	*12 790	8 440	*10 290	6 140	7 890	4 670	*6 390	3 960	10.0
	0 m	kg			*9 020	*9 020	*19 530	12 030	*14 050	8 030	10 140	5 890	7 740	4 530	6 850	4 010	9.8
	-1.5 m	kg	*9 210	*9 210	*13 760	*13 760	*19 950	11 820	14 030	7 820	9 990	5 750	7 670	4 470	7 300	4 260	9.3
	-3.0 m	kg	*14 350	*14 350	*19 900	*19 900	*19 260	11 850	13 990	7 800	9 970	5 730			8 250	4 810	8.6
Boom : 6.45 m GP Arm : 3.9 m GP Shoe : 700 mm CWT : 7 000 kg	9.0 m	kg												*6 290	*6 290	7.3	
	7.5 m	kg								*7 200	7 170			*5 870	5 770	8.5	
	6.0 m	kg								*7 520	7 040	*7 030	5 120	*5 730	4 870	9.2	
	4.5 m	kg							*9 190	*9 190	*8 280	6 780	*7 800	5 010	*5 780	4 350	9.7
	3.0 m	kg					*14 580	13 770	*11 030	9 010	*9 280	6 460	8 080	4 850	*6 000	4 070	10.0
	1.5 m	kg					*17 780	12 650	*12 790	8 440	*10 290	6 140	7 890	4 670	*6 390	3 960	10.0
	0 m	kg			*9 020	*9 020	*19 530	12 030	*14 050	8 030	10 140	5 890	7 740	4 530	6 850	4 010	9.8
	-1.5 m	kg	*9 210	*9 210	*13 760	*13 760	*19 950	11 820	14 030	7 820	9 990	5 750	7 670	4 470	7 300	4 260	9.3
	-3.0 m	kg	*14 350	*14 350	*19 900	*19 900	*19 260	11 850	13 990	7 800	9 970	5 730			8 250	4 810	8.6

Notes: 1. Machine in "Fine Mode-F" (Power Boost) for lifting capacities. 2. The above loads are in compliance with SAE J1097 and ISO 10567 Hydraulic Excavator Lifting Capacity Standards. 3. Rated loads do not exceed 87% of hydraulic lifting capacity or 75% of tipping load. 4. Rated loads marked with an asterisk (*) are limited by hydraulic capacity rather than tipping load.

Equipment

STANDARD EQUIPMENT

Engine

Turbocharged, four stroke diesel engine with water cooling, direct injection and charged air cooler that meets EU Stage V requirements

Air filter with indicator

Air intake heater

Cyclone pre-cleaner

Electric engine shut-off

Fuel filter and water separator

Fuel filler pump: 50 l/min, with automatic shut-off

Alternator, 120 A

Hybrid

Accumulator, 26 l

Boom regeneration valves

Assist motor

Main pump with PTO

Electric / Electronic control system

Advanced mode control system

Self-diagnostic system

Machine status indication

Engine speed sensing power control

Automatic idling system

Onetouch power boost

Safety stop/start function

Adjustable LCD color monitor

Master electrical disconnect switch

Engine restart prevention circuit

High-capacity LED lights:

- Frame-mounted 2

- Boom-mounted 2

Batteries, 2 x 12 V / 200 Ah

Start motor, 24 V / 5.5 kW

Frame

Access way with handrail

Tool storage area

Punched metal anti-slip plates

Counterweight: 7 000 kg

Undercarriage

Undercover (heavy-duty)

Hydraulic track adjusters

Greased and sealed track link

Track Guard

Hydraulic system

Boom up swing priority function

Boom travel priority function (Creep)

Boom down speed control

Hose rupture valve: boom & arm

Overload warning device

Automatic sensing hydraulic system

- Summation system

- Boom priority

- Arm priority

- Swing priority

ECO mode fuel saving technology

Boom, arm and bucket regeneration valves

Swing anti-rebound valves

Boom and arm holding valves

Multistage filtering system

Cylinder cushioning

Cylinder contamination seals

Auxiliary hydraulic valve

Automatic twospeed travel motors

Hydraulic oil, ISO VG 46

STANDARD EQUIPMENT

Cab and interior

ROPS (ISO 12117-2) certified cab

Silicon oil and rubber mounts with spring

Travel pedals and hand levers

Adjustable operator seat and joystick control console

Proportional joysticks with 3 switches each

Heater & air-conditioner, automatic

Flexible antenna

Radio with MP3 & USB Jack with bluetooth

Hydraulic safety lock lever

Cab, allweather sound suppressed, includes:

- Cup holders

- Door locks

- Tinted glass

- Floor mat

- Horn

- Large storage area

- Pull-up type front window

- Removable lower windshield

- Seat belt

- Safety glass

- Sun screens, front, roof, rear

- Rain shield

- Windshield wiper with intermittent feature

Rear view camera

Side view camera

Master key

Track shoes

600 mm with triple grousers

Digging equipment

Boom: 6.45 m

Arm: 3.2 m

Manual centralized lubrication

OPTIONAL EQUIPMENT

Engine

Block heater: 240 V

Oil bath pre-cleaner

Diesel coolant heater, 10 kW

Water separator with heater

Auto engine shutdown

Reversible fan

Delayed engine shutdown

Electric

Extra work lights (Halogen or LED):

- Cab-mounted 3

- Boom-mounted 2

- Counterweight-mounted 1

Green light beacon

Travel alarm

Anti-theft system

Rotating warning beacon

Frame

Foldable Cabin Entrance

Foldable Walkway

Undercarriage

Full track guard

OPTIONAL EQUIPMENT

Hydraulic system

CDC, Comfort Driving Control
Boom float function
Attachment management system (up to 32 programmable memories) - Variable flow and pressure pre-setting
Hammer & shear, 1 and 2 pump flow
Additional return filter
Hydraulic piping: - Slope & rotator
- Grapple
- Oil leak (drain) line
Quick coupler piping
Volvo hydraulic quick coupler S3
Volvo hydraulic quick coupler U38
Hydraulic oil, biodegradable 46
Hydraulic oil, longlife oil 32
Hydraulic oil, longlife oil 46
Hydraulic oil, longlife oil 68
Fuel tank-fast fuel fill prep
Straight travel pedal
Machine control system
Dig Assist
Volvo Active Control (Semi-autonomous)
Please refer to separate Brochure for more details

OPTIONAL EQUIPMENT

Cab and interior

Fabric seat with heater
Fabric seat with heater and air suspension
Deluxe seat
High-strength one piece front windshield (P5A)
Opening top hatch
Falling object guard, FOG (fixed type or hinge type) - Frame-mounted - Cab-mounted
Cab-mounted falling object protective structure (FOPS)
Volvo smart view
Smoker kit (ashtray and lighter)
Safety net for front window
Lower wiper with intermittent control
Anti-vandalism kit
Specific key
Cleaning air gun
Track shoes
700/800/900 mm with triple grousers
600 mm HD with triple grousers
600 mm with double grousers
Digging equipment
Boom: 6.45 m HD
Arm: 2.6 m HD, 3.2 m HD, 3.9 m
Linkage with lifting eye
Service
Tool kit, daily maintenance
Tool kit, full scale

SELECTION OF VOLVO OPTIONAL EQUIPMENT

Foldable walkways and foldable cab entrance**Air gun****Deluxe seat****Comfort Drive Control****High-strength one-piece front windshield**

Not all products are available in all markets. Under our policy of continuous improvement, we reserve the right to change specifications and design without prior notice. The illustrations do not necessarily show the standard version of the machine.

VOLVO

Volvo Construction Equipment

volvoce.com