

Volvo Construction Equipment
Building Tomorrow



EW180E, EW220E

Volvo Excavators 18.7-20.8 t 129 kW, 20.3-23.4 t 129 kW



Perform with precision

Efficient and versatile, the EW180E and EW220E offer continuous productivity and all the proven Volvo technology you'd expect from the E-Series wheeled excavator. Get ready to work with the powerful machines, offering precise movements to help you maintain total control and performance.

Hydraulic performance

Take on any application with the improved load-sensing hydraulic system that allows maximum utilization of available engine power, increasing controllability and responsiveness. When climbing gradients and travelling over unstable ground, rely on the proven travel motor to provide the tractive force you need.



Comfort at speed

Experience ultimate control and enhanced comfort while traveling at high speeds. The optional Boom Suspension System automatically engages at 5km/h, absorbing shocks to reduce bouncing and bucket spillage. The hydraulic circuit, complete with gas pressure dampeners, softens the vibrations when driving over rough terrain or bumpy roads for smoother travel.



The right configuration for the job

Carry out a variety of tasks with optional configurations. The machines are offered with a hitch, so you can pull trailers weighing 3 tons, or up to 8 tons with additional dry run brakes. You can fit the trailer hook onto the outriggers or parallel blade, to optimize machine versatility. And, with a wide range of high quality tires, available in both single and twin, you're ready to tackle all types of ground conditions.



Do more

Unlock the full potential of your E-Series wheeled excavator with optional auxiliary lines to power your attachments. The breaker/shear function (X1) uses the main hydraulic system to provide optimum flow when operating attachments requiring one or two-way flow, while the tilt/rotate function (X3) delivers an appropriate two-way flow.



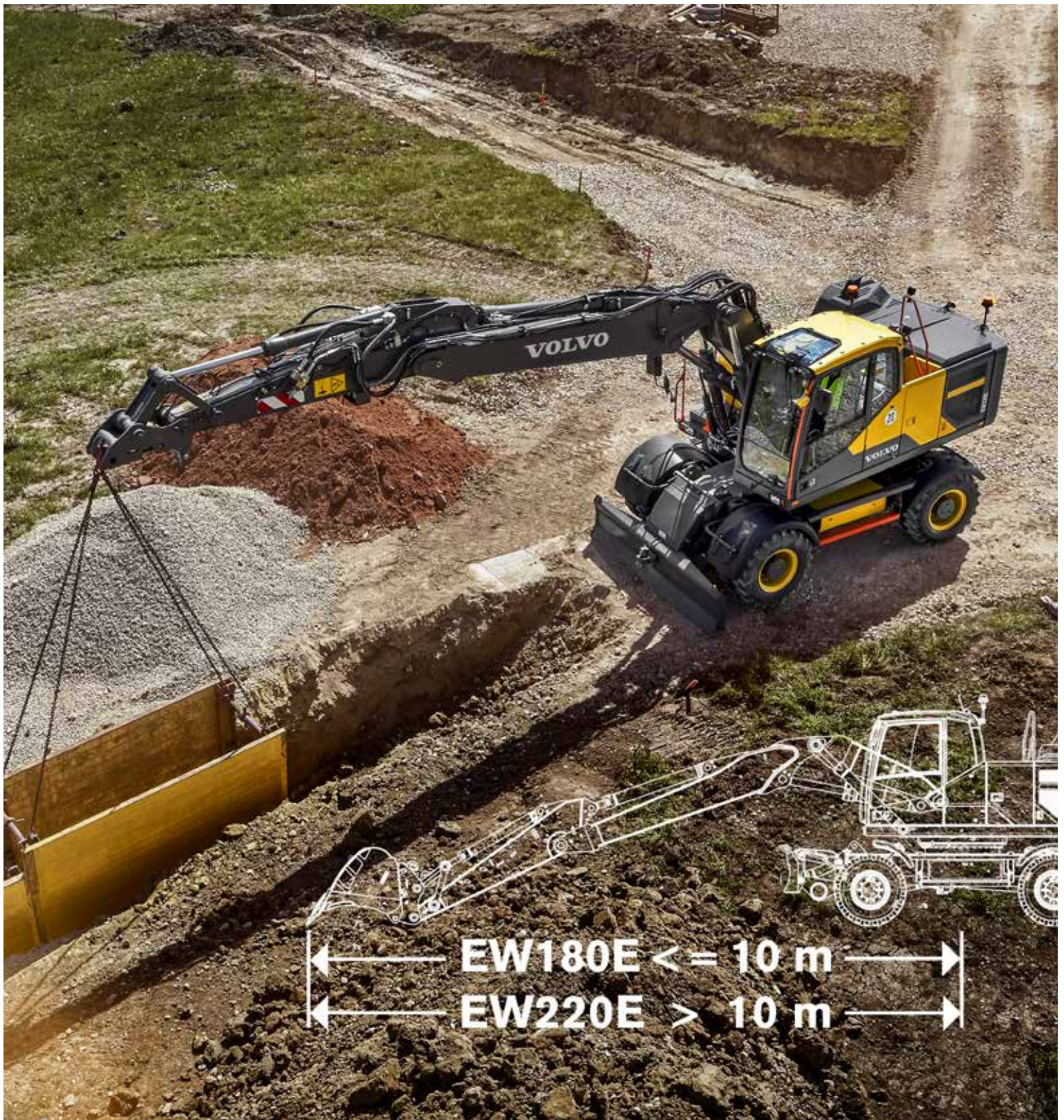

REACH FURTHER, LIFT MORE

Boost your working ability with the new heavy-duty two-piece boom and arm, designed to stretch further, dig deeper and reach higher. In an industry that's always evolving, with growing business demands, the EW180E and EW220E excavators offer a total reach of over 10 meters and increased lifting capacity.



SUPERIOR SERVICEABILITY

It's easy to keep your machines up and running with simple serviceability. Find greasing points grouped together and filters placed behind wide-opening engine doors, to provide ground-level access to daily service checkpoints. Meanwhile, the pivoting AC condenser is fixed with two flexible latches, improving access to the mesh and radiators for cleaning, increasing component life.

Maximize your uptime

Optimize machine uptime with the EW180E and EW220E, rigorously tested and proven to withstand the test of time. Equipped with a powerful Volvo engine, the wheeled excavators always deliver an efficient and reliable operation, so you can keep your fuel consumption low and productivity high. Durable by design, the machines offer simple servicing, helping you get back on track – fast.

On or off road

Whether you require a wheeled excavator for on or off road operations, Volvo flexible design ensures you're always ready for action. The EW220E is available from the factory as either road homologated or off-road version – the off-road design boasting a heavier counterweight.



Power up, fuel down

Get the bigger jobs done better and faster. Equipped with a powerful Volvo engine, delivering higher torque at lower rpm, the E-Series offers superior performance. To reduce fuel consumption, ECO mode turns on automatically. This is enhanced by auto idle and auto engine shut down, which engage after a pre-set amount of time, also helping to reduce machine wear.



Strength and durability

The EW180E and EW220E are built with protected components and a strong frame structure, for sustained uptime and increased machine life. The specially designed undercarriage offers high clearance when driving over hard ground, while the robust axles – equipped with automatic or operator controlled front axle oscillation – offer strength in demanding applications.



Automatic digging brake

Maximize uptime with the optional automatic digging brake, first introduced by Volvo. The service brake and oscillation lock automatically engage when the machine's speed is at zero, so you can get straight to work once you stop.



Comfortable and convenient

Conveniently designed to make life easier on the jobsite, the E-Series wheeled excavators are equipped with the latest features to increase operator comfort and productivity. Take on the most demanding working environments from the comfort of the spacious Volvo cab, boasting all-around visibility and ergonomically-positioned controls for enhanced controllability.

Comfort Drive Control

New for the Volvo wheeled excavator range, Comfort Drive Control gives the operator the opportunity to control the machine using only the joystick, up to 20km/h.



Safe from the inside out

Stay safe when operating in tough environments in the ROPS certified Volvo cab, and increase visibility using the rear view and side view cameras – which come as standard. In addition, you can select the optional Volvo Smart View to enjoy a bird's-eye-view of the operation in real-time. Find your way easily around the outside of cab, guided by the bright orange handrails.



Operator convenience

Take all your tools to the jobsite in just one trip, with the homologation approved trailer hitch. Carrying up to 120kg, the optional drawer type toolbox has been designed with interchangeable box dividers and stoppers to prevent sliding during operation. Fill your excavator with ease from ground level using the electric fuel filler pump, delivering 50 liters of fuel per minute.



Operators choice

Enjoy a comfortable ride in the low-noise Volvo cab. The ergonomically-positioned interface – including the joysticks, keypad and LCD monitor – helps you stay alert and focused. As an option, the EW220E can be ordered from factory without the steering column, to boost further visibility (not homologated for road use).





ENHANCED CONTROLLABILITY

The E-Series wheel excavators offers an array of functions at your fingertips. You can now control the entire machine from the joysticks, including the tiltrotator, blade and outriggers. For easy operation and maximum productivity, the digital colour display newly combines machine and tiltrotator information.

Intelligent design, smart choice

REACH FURTHER, LIFT MORE

The new heavy-duty two-piece boom and arm offers a total reach of over 10 meters and increased lifting capacity.

Automatic digging brake

The automatic digging brake engages when the machine's speed is at zero, so you can get straight to work once you stop.

Hydraulic performance

The improved load-sensing hydraulic system allows maximum utilization of available engine power for increased responsiveness of operations.

STEELWRIST® TILTROTATOR

The factory-fitted Steelwrist® tiltrotator offers ultimate control using the new joysticks and machine display.

Strength and durability

The EW180E and EW220E offer strength in demanding applications with the specifically designed undercarriage and robust axles.



Match and attach

Customize your machine with a range of purpose-built quality attachments, for improved cycle times and increased fuel efficiency.

ENHANCED CONTROLLABILITY

Experience ultimate control of the entire machine from the joysticks, including steering (CDC), tiltrotator, blade and outriggers.

Safe from the inside out

Operate safely in the ROPS certified Volvo cab, fit with rear view and side view cameras – which come as standard.

Power up, fuel down

ECO mode, auto idle and auto engine shut down turn on automatically to reduce fuel consumption and machine wear.

Operators choice

The low-noise Volvo cab offers a comfortable and spacious ride with all-around visibility and ergonomically positioned interface.

Comfort Drive Control

Comfort Drive Control gives the operator the opportunity to control the machine using only the joystick, up to 20km/h.



On or off road

The EW220E is available from the factory as either road homologated or off-road version.

SUPERIOR SERVICEABILITY

Greasing points are grouped together for fast maintenance and filters placed behind wide-opening engine doors.

The complete package

To ensure your business runs smoothly, Volvo invests in the intelligent engineering of every machine – but we don't stop there. As your partner in production, we support what you do with the right equipment for the job. Our portfolio of attachments and services is designed to complement your machine's performance and boost your profitability.

Ditching buckets

For superior performance, Volvo ditching buckets make the perfect partner for landscaping, slope shaping or ditch maintenance. Featuring a 45° tilting on both sides, the Tilttable Ditching bucket is the ideal choice when a clean, smooth grade is required.

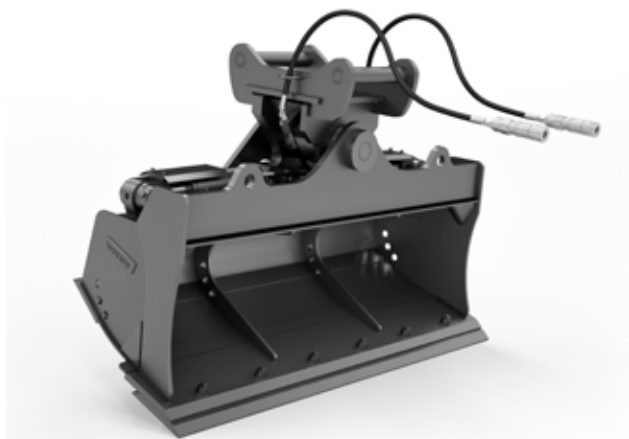

Match and attach

Get the most out of your wheeled excavator with our range of purpose-built attachments, designed to work in perfect harmony with your machine. Form one solid and reliable unit that delivers improved cycle times and increased fuel efficiency, by customizing your machine with quality attachments that match your needs.



Machine monitoring made easy

Stay ahead of unscheduled downtime and check that your machine is being operated efficiently with CareTrack – the state-of-the-art telematics system. Stay informed and receive reports, alarms and information such as fuel status, machine location and hours, so you can plan your service more efficiently.



Here to support you

Maintain productivity and machine uptime with our range of widely available, tested and approved Genuine Volvo Parts – all backed by Volvo warranty. Here with the complete solution, we'll help you stay on track, offering flexible maintenance and repair options, as well as planned servicing, to extend the life of your excavator.





STEELWRIST® TILTROTATOR

Boost productivity with the Steelwrist® tiltrotator, offering ultimate control. The factory-fitted system gives you the power to control both the machine and tiltrotator using only the two joysticks, with the information presented on just one machine display. Volvo digging, grading and cable buckets are designed to work in harmony with the tiltrotator. (Steelwrist® is a registered trademark of Steelwrist AB)

Volvo EW180E in detail

Engine

Volvo Construction Equipment is ready to comply with the tough new EU Stage V legislation for off-road vehicles with the introduction of a cascade of innovations in its new generation engines with Volvo Advanced Combustion Technology (V-ACT).

Volvo machines are equipped with in-line turbo charged diesel engine with high pressure unit injector system. The engine features a externally cooled exhaust gas re-circulation (E-EGR), a Diesel Particulate Filter (DPF) and a Selective Catalytic Reduction (SCR) with AdBlue®.

Engine	Volvo	D6J
Max. power at	r/min	1 800
Net (ISO9249/SAEJ1349)	kW	126
	hp	171
Gross (ISO 14396/SAE J1995)	kW	129
	hp	175
Max. torque	Nm	850
at engine speed	r/min	1 350
No. of cylinders		6
Displacement	l	5.7
Bore	mm	98
Stroke	mm	126

Electrical system

High-capacity electrical system that is well protected. Waterproof double-lock harness plugs are used to secure corrosion-free connections. The main relays and solenoid valves are shielded to prevent damage. The master switch is standard.

Voltage	V	24
Batteries	V	2 x 12
Battery capacity	Ah	2 x 140
Alternator	V/Ah	28/120

Undercarriage

Drive train: A variable axle piston motor in combination with a power shift gearbox supplies 3 speeds. The gearbox distributes than the energy via propeller shafts to the axles.

Framework: All-welded robust torsion box frame.

Wheels: Alternative single and twin wheels available.

Front axle: Robust excavator axle with automatic or operator controlled front axle oscillation lock.

Undercarriage available with all possible combinations of bolted outriggers and / or parallel blade.

Oscillation	± °	10
with mudguards	± °	7
Twin wheels	type	10-20
Tractive force (net)	kN	111
Travel speed, on road	km/h	20.0/30.0/35.0
Travel speed, off road	km/h	5.0/7.4/8.9
Travel speed, creep	km/h	3.7
Min. turning radius	m	7.6

Brake system

Service brakes: servo-hydraulically manoeuvred self-adjusting wet multidiscs with two separate brake circuits.

Parking brake: negative wet disc in gear housing, spring applied and pressure released.

Digging brake: service brake with mechanical lock system.

Security system: The 2-circuit travel brakes are supplied with two accumulators in the event of failure in the service brake system.

Cab

New design Volvo Care Cab with operator protective structure, large and roomy interior. One way travel pedal with rocker switch control (F-N-R) on the right joystick. One-touch release for digging brake pedal.

Audio system with remote control and Bluetooth system for hands free phoning. Independently adjustable joystick consoles.

Excellent all-round visibility provided by maximized cab class, transparent roof hatch, 2-piece sliding door window and long stroke, easy to adjust and narrow steering column. The liftable front windshield can easily be stored in the inside roof space and clipped in position. The removable lower front glass can be stored in the side door pocket. Interior lighting consists of one reading light and one light with timer.

The pressurized and filtered cab air is supplied by a 14-vent climate-control providing fast defrosting and high cooling and heating performance.

Viscous/ spring mounted suspension cushions protect the operator from vibrations. Deluxe air-suspension seat with adjustable seat suspension, height, tilt, recline and forward-backward settings.(option)

Adjustable, easy to read 8.3" LCD color monitor provides real time information of machine functions and important diagnostic information and is switchable to rear view camera monitor(standard) / side view camera (option). A new multi function button on left hand joystick with programmable function to improve the operator comfort.

Refrigerant of the type R134a is used when this machine is equipped with air conditioning. Contains fluorinated greenhouse gas R134a, Global Warming Potential 1.430 t CO₂-eq.

Hydraulic system

Closed-centre load sensing hydraulic system with pressure compensated valves. Load independence of movements. Flow sharing feature, combined with a high flow pump (power regulation). The system gives superior manoeuvrability and fast movements, for optimal working result and economy. The following working modes are included in the system:

Parking mode (P): Parking position for optimal safety.

Travel mode (T): Engine speed is controlled by travel pedal stroke for low fuel consumption and noise.

Working mode (W): Full working flow with adjustable engine rpm for normal working and best speed utilisation.

Customer mode (C): Operator can set proper oil flow in accordance with job conditions.

Power Boost: All digging and lifting forces are increased.

Main pump (type low noise axial piston pump)

Max. flow	l/min	375
-----------	-------	-----

Servo pump (type low noise gear pump)

Max. flow	l/min	15
-----------	-------	----

Brake + steering pump (Low noise gear pump)

Max. flow	l/min	48
-----------	-------	----

Relief valve setting pressure

Implement	MPa	34/37.5
Travel system	MPa	37.5
Slew system	MPa	23
Pilot system	MPa	3.5

Swing system

The superstructure is slewed by the means of a axial motor with reduction gear box.

Automatic slew holding brake and anti-rebound valve are standard.

Max. slew speed	r/min	9
Max. slew torque	kNm	54

Total Machine Weights

Machine with 5.2 m mono boom, 2.45 m dipper arm, quickfit S1, 590 kg / 890 l bucket.		
With dozer blade front and outriggers rear	kg	19 900
With dozer blade rear only	kg	18 700
With front and rear outriggers	kg	20 220
Machine with 5.47 m 2-piece boom, 2.45 m dipper arm, quickfit S1, 590 kg / 890 l bucket.		
With dozer blade front and outriggers rear	kg	20 500
With dozer blade rear only	kg	19 300
With front and rear outriggers	kg	20 820

Service Refill

Fuel tank	l	290
DEF/AdBlue® tank	l	25
Hydraulic system, total	l	300
Hydraulic tank	l	165
Engine oil	l	25
Engine coolant	l	33
Transmission	l	2.5
Axle differential:		
Front axle	l	9.5
Rear axle	l	12.5

Sound Level

Sound pressure level in cab according to ISO 6396		
L _{pA}	dB	70
External sound level according to ISO 6395 and EU Noise Directive 2000/14/EC		
L _{WA} (standard)	dB	101
L _{WA} (tropical)	dB	102

Volvo EW220E in detail

Engine

Volvo Construction Equipment is ready to comply with the tough new EU Stage V legislation for off-road vehicles with the introduction of a cascade of innovations in its new generation engines with Volvo Advanced Combustion Technology (V-ACT).

Volvo machines are equipped with in-line turbo charged diesel engine with high pressure common rail system. The engine features a externally cooled exhaust gas re-circulation (E-EGR), a Diesel Particulate Filter (DPF) and a Selective Catalytic Reduction (SCR) with AdBlue®/Diesel exhaust fluid (DEF).

Engine	Volvo	Volvo D6J
Max. power at	r/min	1 800
Net (ISO9249/SAEJ1349)	kW	126
	hp	171
Gross (ISO 14396/SAE J1995)	kW	129
	hp	175
Max. torque	Nm	850
at engine speed	r/min	1 350
No. of cylinders		6
Displacement	l	5.7
Bore	mm	98
Stroke	mm	126

Electrical system

High-capacity electrical system that is well protected. Waterproof double-lock harness plugs are used to secure corrosion-free connections. The main relays and solenoid valves are shielded to prevent damage. The master switch is standard.

Voltage	V	24
Batteries	V	2 x 12
Battery capacity	Ah	2 x 140
Alternator	V/Ah	28/120

Undercarriage

Drive train: A variable axle piston motor in combination with a power shift gearbox supplies 3 speeds. The gearbox distributes the energy via propeller shafts to the axles.

Framework: All-welded robust torsion box frame.

Wheels: Alternative single and twin wheels available.

Front axle: Robust excavator axle with automatic or operator controlled front axle oscillation lock.

Undercarriage available with all possible combinations of bolted outriggers and / or parallel blade.

Oscillation	± °	10
with mudguards	± °	7
Twin wheels	type	10-20
Tractive force (net)	kN	121
Travel speed, on road	km/h	20 / 25 / 30
Travel speed, off road	km/h	5.0 / 6.4 / 7.4
Travel speed, creep	km/h	3.2
Min. turning radius	m	8.1

Travel speeds may depend on to local regulations.

Brake system

Service brakes: servo-hydraulically manoeuvred self-adjusting wet multidiscs with two separate brake circuits.

Parking brake: negative wet disc in gear housing, spring applied and pressure released.

Digging brake: service brake with mechanical lock system.

Security system: The 2-circuit travel brakes are supplied with two accumulators in the event of failure in the service brake system.

Cab

New design Volvo Care Cab with operator protective structure, large and roomy interior. One way travel pedal with rocker switch control (F-N-R) on the right joystick. One-touch release for digging brake pedal.

Audio system with remote control and Blue tooth system for hands free phoning. Independently adjustable joystick consoles.

Excellent all-round visibility provided by maximized cab class, transparent roof hatch, 2-piece sliding door window and long stroke, easy to adjust and narrow steering column. The liftable front windshield can easily be stored in the inside roof space and clipped in position. The removable lower front glass can be stored in the side door pocket. Interior lighting consists of one reading light and one light with timer.

The pressurized and filtered cab air is supplied by a 14-vent climate-control providing fast defrosting and high cooling and heating performance.

Viscous/spring mounted suspension cushions protect the operator from vibrations. Deluxe air-suspension seat with adjustable seat suspension, height, tilt, recline and forward-backward settings. (option)

Adjustable, easy to read 8.3" LCD color monitor provides real time information of machine functions and important diagnostic information and is switchable to rear view camera monitor(standard) / side view camera (option). A new multi function button on left hand joystick with programmable function to improve the operator comfort.

Refrigerant of the type R134a is used when this machine is equipped with air conditioning. Contains fluorinated greenhouse gas R134a, Global Warming Potential 1.430 t CO₂-eq.

Hydraulic system

Closed-centre load sensing hydraulic system with pressure compensated valves. Load independence of movements. Flow sharing feature, combined with a high flow pump (power regulation). The system gives superior manoeuvrability and fast movements, for optimal working result and economy.

The following working modes are included in the system:

Parking mode (P): Parking position for optimal safety.

Travel mode (T): Engine speed is controlled by travel pedal stroke for low fuel consumption and noise.

Working mode (W): Full working flow with adjustable engine rpm for normal working and best speed utilisation.

Customer mode (C): Operator can set proper oil flow in accordance with job conditions.

Power Boost: All digging and lifting forces are increased.

Main pump (type low noise axial piston pump)

Max. flow	l/min	375
-----------	-------	-----

Servo pump (type low noise gear pump)

Max. flow	l/min	15.2
-----------	-------	------

Brake + steering pump (type low noise gear pump)

Max. flow	l/min	48
-----------	-------	----

Relief valve setting pressure

Implement	MPa	34.0 / 37.5
Travel system	MPa	37.5
Slew system	MPa	27
Pilot system	MPa	3.5

Swing system

The superstructure is slewed by the means of a axial motor with reduction gear box.

Automatic slew holding brake and anti-rebound valve are standard.

Max. slew speed	r/min	9
Max. slew torque	kNm	63

Total Machine Weights

Total machine weight: road homologated / off road
Machine with 5.72 m 2- piece boom, 2.45 m dipper arm, Quick Fit S1 810 kg /1350 l bucket

With dozer blade and Outrigger	kg	22 200 / 23 100
With front and rear outriggers	kg	22 500 / 23 400
With parallel blade rear only	kg	20 900 / 21 800

Total machine weight: road homologated / off road
Machine with 5.7 m Mono boom, 2.45 m dipper arm, Quick Fit S1 810 kg /1350 l bucket

With dozer blade and Outrigger	kg	21 600 / 22 500
With front and rear outriggers	kg	21 900 / 22 800
With parallel blade rear only	kg	20 300 / 21 200

Service Refill

Fuel tank	l	290
DEF/AdBlue® tank	l	25
Hydraulic system, total	l	340
Hydraulic tank	l	170
Engine oil	l	25
Engine coolant	l	33
Swing reduction unit	l	7
Transmission	l	2.5
Axle differential:		
Front axle	l	14.6
Rear axle	l	19.5

Sound Level

Sound pressure level in cab according to ISO 6396		
L _{pA} (standard)	dB	70
L _{pA} (tropical)	dB	70
External sound level according to ISO 6395 and EU Noise Directive 2000/14/EC		
L _{WA} (standard)	dB	101
L _{WA} (tropical)	dB	102

Specifications

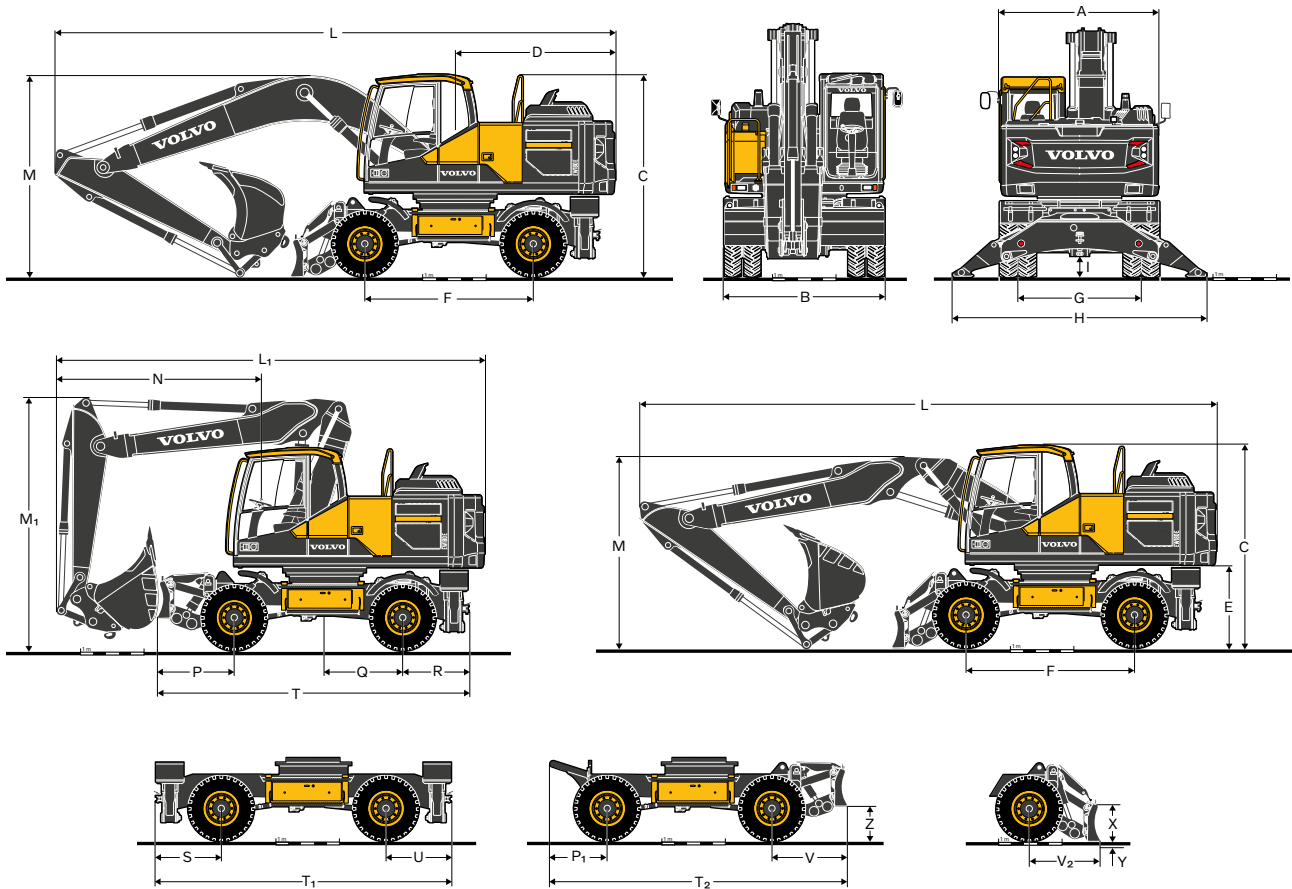

DIMENSIONS

Model		EW180E		EW220E	
Description	Unit	Mono boom	2-piece boom	Mono boom	2-piece boom
	m	5.2	5.47	5.7	5.72
A	Overall width of superstructure	mm	2 520	2 520	2 520
B	Overall width	mm	2 540 / 2 750***	2 540 / 2 750***	2 540 / 2 750
C	Overall height of cab	mm	3 190	3 190	3 190
D	Tail slew radius	mm	2 550	2 550	2 624
E	Counterweight clearance	mm	1 280	1 280	1 295
F	Wheel base	mm	2 650	2 650	2 750
G	Tread	mm	1 940	1 940	1 914 / 2 114
H	Outrigger width (front or rear)	mm	4 000	4 000	4 020
I	Min. ground clearance	mm	333	333	334

*** For EW180E machines only: equipped with twin HBI Delcora tires 315/70 R 22.5: dimension B = 2 560 mm OR with single Alliance tire 620/40R 22.5, dimension B = 2 570 mm

DIMENSIONS

Description		Unit	Mono boom EW180E				2-piece boom EW180E			
		m	5.2				5.47			
			Arm			Grab Arm	Arm			Grab Arm
		m	2.45	2.6	3.0	3.2*	2.45	2.6	3.0	3.2*
L	Overall length	mm	8 880	8 870	8 900	8 830	8 990	8 990	9 020	8 860*
M	Overall height of boom	mm	3 220	3 180	3 480	3 580	3 220	3 200	3 340	3 530*
L ₁	Overall length	mm	-	-	-	-	6 870	6 630**	6 670**	6 720*
M ₁	Overall height of boom	mm	-	-	-	-	3 970	3 940**	3 940**	3 950*
N	Front overhang	mm	-	-	-	-	3 280	3 040**	3 080**	3 130*
			Mono boom EW220E				2-piece boom EW220E			
		m	5.7				5.72			
			Arm			Grab Arm	Arm			Grab Arm
		m	2.45	2.6	2.9	3.2*	2.45	2.6	2.9	3.2*
L	Overall length	mm	9 500	9 500	9 480	9 380	9 500	9 500	9 460	9 330*
M	Overall height of boom	mm	3 090	3 140	3 260	3 520	3 080	3 130	3 250	3 460*
L ₁	Overall length	mm	-	-	-	-	7 180	7 140	7 180**	7 180*
M ₁	Overall height of boom	mm	-	-	-	-	3 970	4 000	3 970**	3 970*
N	Front overhang	mm	-	-	-	-	3 500	3 460	3 500**	3 500*

*grab arm, without clamshell bucket | ** without bucket

UNDERCARRIAGE DIMENSIONS

Description	Unit	EW180E	EW220E
P	mm	1 210	1 290
P ₁	mm	780	830
Q	mm	1 220	1 370
R/U	mm	1 040	1 070
S	mm	1 130	1 160
T	mm	4 900	5 320
T ₁	mm	4 820	4 980
T ₂	mm	4 560	4 780
V	mm	1 130	1 200
V ₂	mm	960	980
X	mm	600	600
Y	mm	155	120
Z	mm	470	460

Specifications

EW180E

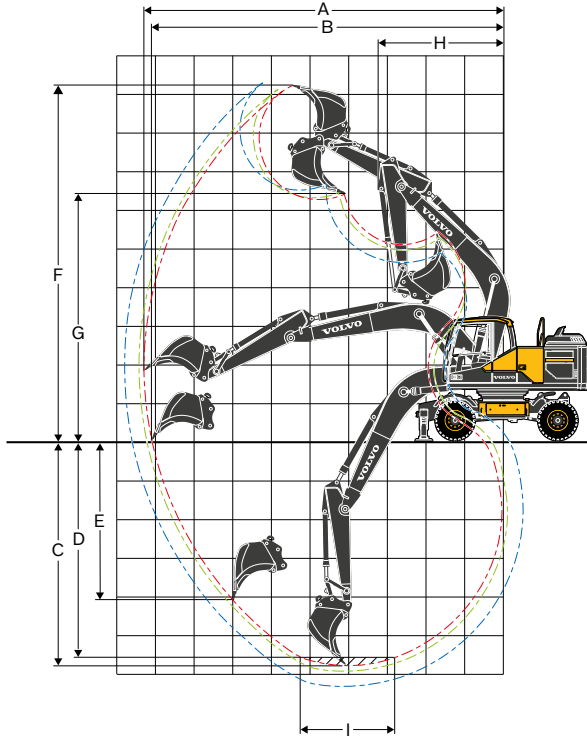

Mono boom 5.2 m and dipper arm 2.45 m, 2.6 m, 3.0 m

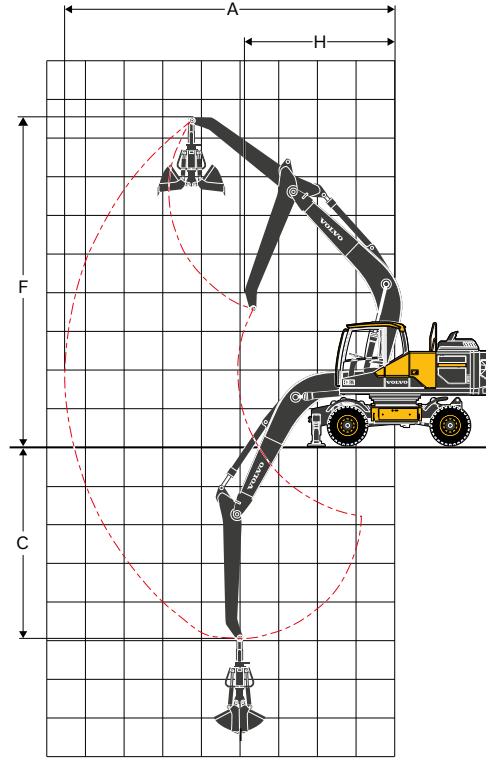

Mono boom 5.2 m and grab arm 3.2 m

WORKING RANGES WITH DIRECT FIT BUCKET

		Unit	5.2 m mono boom EW180E			
			Arm			Grab arm
			2.45	2.6	3.0	3.2
A	Max. digging reach	mm	9 400	9 530	10 000	8 420
B	Max. digging reach on ground	mm	9 200	9 350	9 735	-
C	Max. digging depth	mm	5 540	5 690	6 100	4 680
D	Max. digging depth (l=2.44m level)	mm	5 355	5 510	5 930	-
E	Max. vertical wall digging depth	mm	4 700	4 855	5 235	-
F	Max. cutting height	mm	9 720	9 820	10 070	8 500
G	Max. dumping height	mm	6 530	6 630	6 880	-
H	Min. front slew radius	mm	2 990	3 010	3 050	3 710

DIGGING FORCES WITH DIRECT FIT BUCKET

Breakout force (bucket)	ISO	kN	132*	132*	132*	-
Tearout force (arm)	ISO	kN	106*	102*	92*	-

* with powerboost

Max. recommended sizes for direct fit buckets

GP-Bucket (1.8t/m ³)	l	1 000	1 000	870	-
HD-Bucket (2.1t/m ³)	l	700	700	700	-

Max. recommended sizes for quick fit buckets

S1/S70 QF GP-Bucket (1.8 t/m ³)	l	870	870	780	-
S1/S70 QF HD-Bucket (2.1 t/m ³)	l	700	700	700	-
UQF GP-Bucket (1.8 t/m ³)	l	870	870	780	-
UQF HD-Bucket (2.1 t/m ³)	l	700	700	620	-

Note: 1. Bucket size based on SAE-J296, heaped material with a 1:1 angle of repose. 2. "Max permitted sizes" are for reference only and are not necessarily available from the factory.

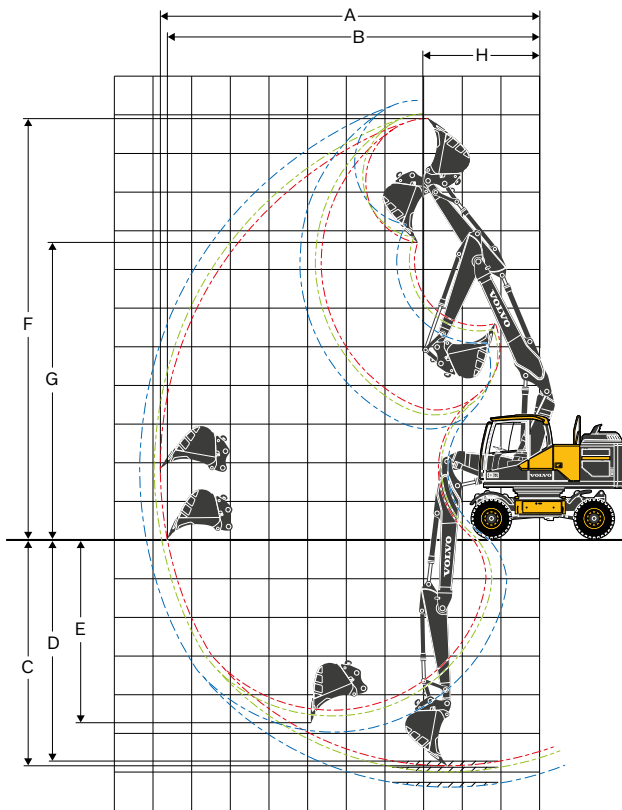

2-piece boom 5.47 m and dipper arm 2.45 m, 2.6 m, 3.0 m

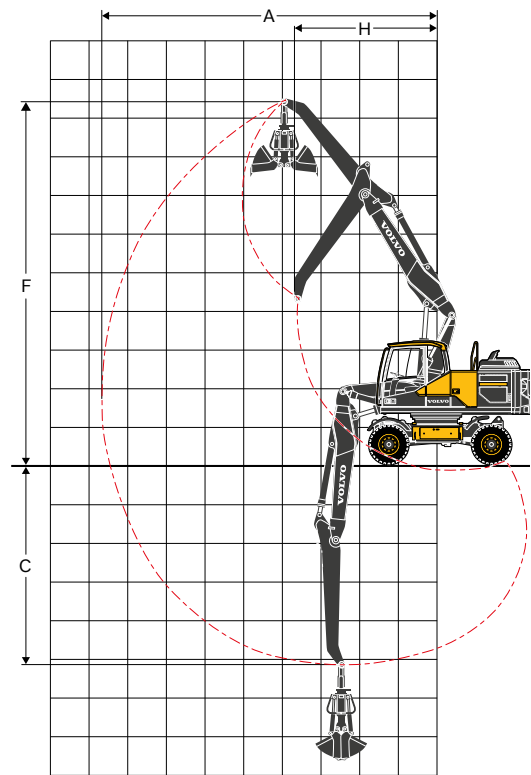

2-piece boom 5.47 m and grab arm 3.2 m

WORKING RANGES WITH DIRECT FIT BUCKET

		Unit	5.47 m 2 piece boom EW180E			
			Arm			Grab arm
		m	2.45	2.6	3.0	3.2
A	Max. digging reach	mm	9 770	9 920	10 310	8 840
B	Max. digging reach on ground	mm	9 600	9 740	10 140	-
C	Max. digging depth	mm	5 860	6 010	6 410	5 000
D	Max. digging depth (l=2.44m level)	mm	5 760	5 920	6 320	-
E	Max. vertical wall digging depth	mm	4 740	4 900	5 280	-
F	Max. cutting height	mm	10 850	10 980	11 320	9 750
G	Max. dumping height	mm	7 650	7 780	8 120	-
H	Min. front slew radius	mm	3 010	3 080	3 240	3 700

DIGGING FORCES WITH DIRECT FIT BUCKET

Breakout force (bucket)	ISO	kN	132*	132*	132*	-
Tearout force (arm)	ISO	kN	106*	102*	92*	-

* with powerboost

Max. recommended sizes for direct fit buckets

GP-Bucket (1.8t/m ³)	l	1 000	870	870	-
HD-Bucket (2.1t/m ³)	l	700	700	700	-

Max. recommended sizes for quick fit buckets

S1/S70 QF GP-Bucket (1.8 t/m ³)	l	870	780	700	-
S1/S70 QF HD-Bucket (2.1 t/m ³)	l	700	700	620	-
UQF GP-Bucket (1.8 t/m ³)	l	870	780	700	-
UQF HD-Bucket (2.1 t/m ³)	l	700	700	620	-

Note: 1. Bucket size based on SAE-J296, heaped material with a 1:1 angle of repose. 2. "Max permitted sizes" are for reference only and are not necessarily available from the factory.

Specifications

EW220E

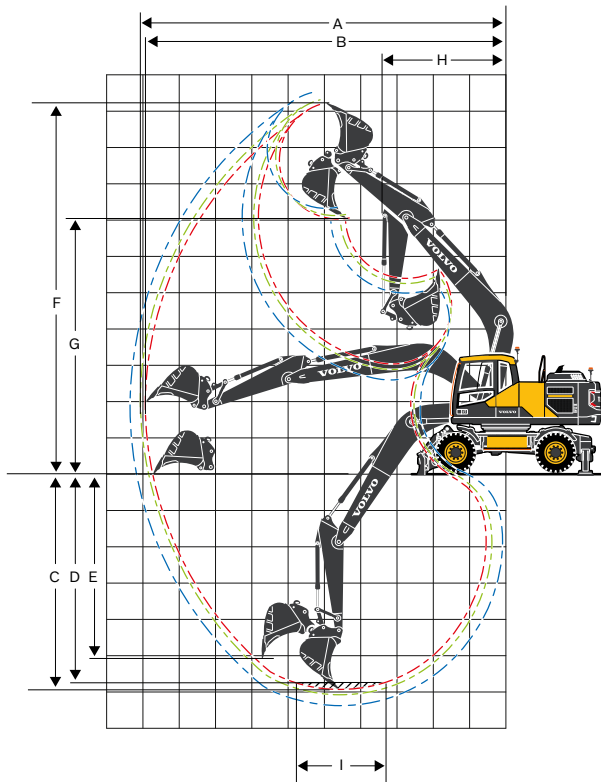

Mono boom 5.7 m and dipper arm 2.45 m, 2.6 m, 2.9 m

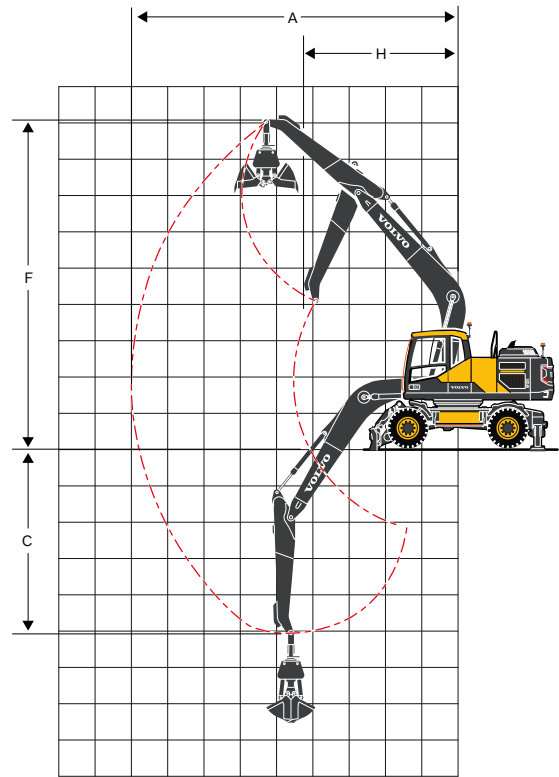

Mono boom 5.7 m and grab arm 3.2 m

WORKING RANGES WITH DIRECT FIT BUCKET

		Unit	5.7 m mono boom EW220E			
			Arm			Grab arm
			2.45	2.6	2.9	3.2
A	Max. digging reach	mm	9 930	10 070	10 360	9 000
B	Max. digging reach on ground	mm	9 750	9 900	10 190	-
C	Max. digging depth	mm	6 010	6 160	6 460	5 150
D	Max. digging depth (l=2.44m level)	mm	5 820	5 980	6 290	-
E	Max. vertical wall digging depth	mm	5 160	5 320	5 611	-
F	Max. cutting height	mm	10 140	10 240	10 440	8 940
G	Max. dumping height	mm	6 950	7 050	7 240	-
H	Min. front slew radius	mm	3 460	3 480	3 530	4 240

DIGGING FORCES WITH DIRECT FIT BUCKET

Breakout force (bucket)	ISO	kN	132*	132*	132*	-
Tearout force (arm)	ISO	kN	122	117	108	-

* with powerboost

Max. recommended sizes for direct fit buckets

GP-Bucket (1.8t/m ³)	l	1 200	1 200	1 000	-
HD-Bucket (2.1t/m ³)	l	1 000	1 000	870	-

Max. recommended sizes for quick fit buckets

S1/S70 QF GP-Bucket (1.8 t/m ³)	l	1 000	1 000	870	-
S1/S70 QF HD-Bucket (2.1 t/m ³)	l	870	870	750	-
UQF GP-Bucket (1.8 t/m ³)	l	1 000	1 000	870	-
UQF HD-Bucket (2.1 t/m ³)	l	870	870	750	-

Note: 1. Bucket size based on SAE-J296, heaped material with a 1:1 angle of repose. 2. "Max permitted sizes" are for reference only and are not necessarily available from the factory.

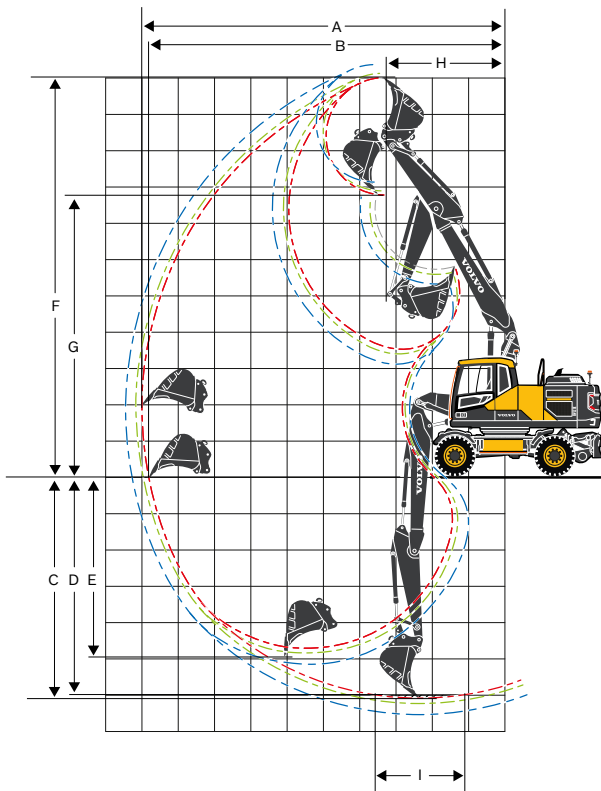

2-piece boom 5.72 m and dipper arm 2.45 m, 2.6 m, 2.9 m

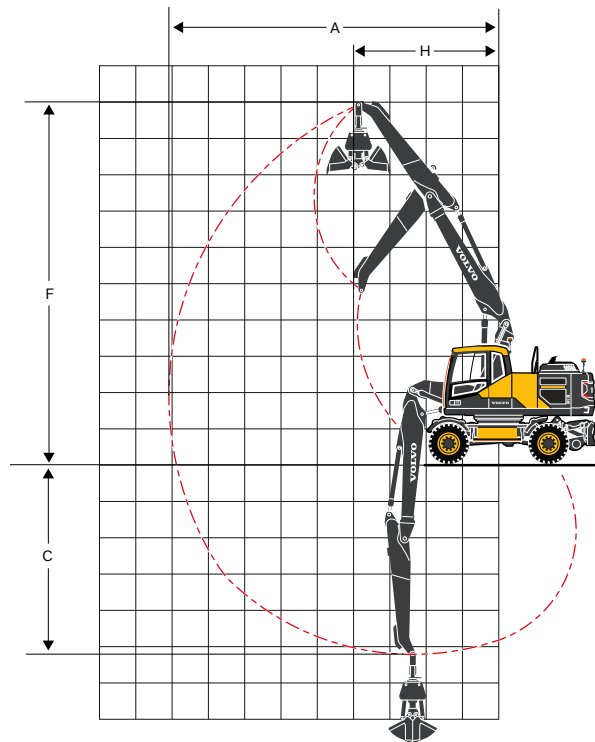

2-piece boom 5.72 m and grab arm 3.2 m

WORKING RANGES WITH DIRECT FIT BUCKET

		Unit	5.72 m 2 piece boom EW220E			
			Arm			Grab arm
		m	2.45	2.6	2.9	3.2
A	Max. digging reach	mm	10 000	10 150	10 440	9 090
B	Max. digging reach on ground	mm	9 630	9 980	10 270	-
C	Max. digging depth	mm	6 160	6 310	6 610	5 290
D	Max. digging depth (l=2.44m level)	mm	6 070	6 220	6 530	-
E	Max. vertical wall digging depth	mm	4 990	5 180	5 480	-
F	Max. cutting height	mm	10 930	11 050	11 300	9 650
G	Max. dumping height	mm	7 720	7 840	8 090	-
H	Min. front slew radius	mm	3 250	3 310	3 430	3 980

DIGGING FORCES WITH DIRECT FIT BUCKET

Breakout force (bucket)	ISO	kN	132*	132*	132*	-
Tearout force (arm)	ISO	kN	122*	117*	108*	-

* with powerboost

Max. recommended sizes for direct fit buckets

GP-Bucket (1.8t/m ³)	l	1 200	1 200	1 000	-
HD-Bucket (2.1t/m ³)	l	1 000	1 000	870	-

Max. recommended sizes for quick fit buckets

S1/S70 QF GP-Bucket (1.8 t/m ³)	l	1 000	1 000	870	-
S1/S70 QF HD-Bucket (2.1 t/m ³)	l	870	870	750	-
UQF GP-Bucket (1.8 t/m ³)	l	1 000	1 000	870	-
UQF HD-Bucket (2.1 t/m ³)	l	870	870	750	-

Note: 1. Bucket size based on SAE-J296, heaped material with a 1:1 angle of repose. 2. "Max permitted sizes" are for reference only and are not necessarily available from the factory.

Specifications

EW180E

LIFTING CAPACITY EW180E

At the arm end, without bucket and quick fit. For lifting capacity including bucket/quick fit, simply subtract actual weight of those parts from the following values. With heavy counterweight. Unit: 1 000kg

	Lifting point	Reach from machine centre (u = support up/d = support down)																									
		1.5 m				3.0 m				4.5 m				6.0 m				7.5 m				Max.					
		Across UC		Along UC		Across UC		Along UC		Across UC		Along UC		Across UC		Along UC		Across UC		Along UC		Across UC	Along UC	Max.			
		u	d	u	d	u	d	u	d	u	d	u	d	u	d	u	d	u	d	u	d	u	d	m			
Mono Boom: 5m Dipper arm: 2.45m Front dozer blade Rear outrigger	7.5	-	-	-	-	-	-	-	-	-	-	-	-	-	-	-	-	-	-	-	-	-	4.2	5.3*	5.3*	5.2	
	6	-	-	-	-	-	-	-	-	-	-	-	-	-	-	-	-	-	-	-	-	-	2.9	4.6*	4.4	4.6*	6.5
	4.5	-	-	-	-	-	-	-	-	5.1	8.5*	7.9	8.5*	3.3	5.5	5.0	7.1*	-	-	-	-	-	2.4	4.0	3.6	4.5*	7.3
	3	-	-	-	-	-	-	-	-	4.7	8.2	7.4	10.2*	3.1	5.3	4.8	7.8*	2.2	3.7	3.4	6.2*	2.1	3.6	3.3	4.5*	7.7	
	1.5	-	-	-	-	-	-	-	-	4.3	7.8	7.0	11.4*	2.9	5.1	4.6	8.4*	2.1	3.6	3.3	6.7*	2.0	3.5	3.2	4.8*	7.8	
	0	-	-	-	-	-	-	-	-	4.1	7.6	6.8	11.6*	2.8	4.9	4.5	8.5*	2.1	3.6	3.3	6.1*	2.1	3.6	3.2	5.4*	7.5	
	-1.5	-	-	-	-	7.4	11.6*	11.6*	11.6*	4.1	7.5	6.7	10.6*	2.8	4.9	4.4	7.8*	-	-	-	-	-	2.3	4.0	3.6	6.1*	7.0
-3	-	-	-	-	7.6	11*	11*	11*	4.1	7.6	6.8	8.3*	-	-	-	-	-	-	-	-	-	2.9	5.0	4.5	5.5*	6.0	
Mono Boom: 5m Dipper arm: 2.6m Front dozer blade Rear outrigger	7.5	-	-	-	-	-	-	-	-	-	-	-	-	-	-	-	-	-	-	-	-	-	4.0	4.9*	4.9*	4.9*	5.4
	6	-	-	-	-	-	-	-	-	-	-	-	-	-	-	-	-	-	-	-	-	-	2.8	4.4*	4.2	4.4*	6.7
	4.5	-	-	-	-	-	-	-	-	5.2	8.2*	8.0	8.2*	3.3	5.5	5.0	7.0*	-	-	-	-	-	2.3	3.8	3.5	4.2*	7.4
	3	-	-	-	-	-	-	-	-	4.7	8.3	7.5	10*	3.1	5.3	4.8	7.7*	2.2	3.7	3.4	6.5*	2.0	3.5	3.2	4.3*	7.8	
	1.5	-	-	-	-	-	-	-	-	4.3	7.8	7.0	11.3*	2.9	5.1	4.6	8.3*	2.1	3.6	3.3	6.6*	2.0	3.4	3.1	4.6*	7.9	
	0	-	-	-	-	5.9*	5.9*	5.9*	5.9*	4.1	7.5	6.8	11.6*	2.8	4.9	4.4	8.5*	2.1	3.6	3.2	6.4*	2.0	3.5	3.1	5.1*	7.7	
	-1.5	-	-	-	-	7.3	11.3*	11.3*	11.3*	4.0	7.5	6.7	10.7*	2.8	4.9	4.4	7.9*	-	-	-	-	-	2.2	3.8	3.5	6*	7.1
-3	-	-	-	-	7.5	11.5*	11.5*	11.5*	4.1	7.5	6.8	8.6*	2.8	4.9	4.5	5.9*	-	-	-	-	-	2.7	4.8	4.3	5.5*	6.2	
Mono Boom: 5m Dipper arm: 3m Front dozer blade Rear outrigger	7.5	-	-	-	-	-	-	-	-	-	-	-	-	-	-	-	-	-	-	-	-	-	3.4	4.1*	4.1*	4.1*	6.0
	6	-	-	-	-	-	-	-	-	-	-	-	-	-	-	-	-	-	-	-	-	-	2.5	3.7*	3.7*	3.7*	7.1
	4.5	-	-	-	-	-	-	-	-	5.2	7.3*	7.3*	7.3*	3.3	5.5	5.0	6.6*	2.3	3.8	3.5	5.2*	2.1	3.5	3.2	3.6*	7.8	
	3	-	-	-	-	-	-	-	-	4.8	8.4	7.6	9.4*	3.2	5.3	4.8	7.4*	2.2	3.8	3.4	6.3*	1.9	3.2	2.9	3.6*	8.2	
	1.5	-	-	-	-	-	-	-	-	4.4	7.9	7.1	11.0*	2.9	5.1	4.6	8.1*	2.1	3.6	3.3	6.5*	1.8	3.1	2.8	3.8*	8.3	
	0	-	-	-	-	6.4*	6.4*	6.4*	6.4*	4.1	7.5	6.7	11.6*	2.8	4.9	4.4	8.4*	2.0	3.6	3.2	6.5*	1.8	3.2	2.9	4.2*	8.1	
	-1.5	6.2*	6.2*	6.2*	6.2*	7.2	10.5*	10.5*	10.5*	4.0	7.4	6.6	11.0*	2.7	4.8	4.4	8.1*	2.0	3.5	3.2	5.7	2.0	3.5	3.2	5*	7.6	
-3	-	-	-	-	7.4*	12.8*	12.8*	12.8*	4.0	7.4	6.7	9.3*	2.7	4.8	4.4	6.7*	-	-	-	-	-	2.4	4.2	3.8	5.4*	6.7	
Mono Boom: 5m Grab arm: 3.2m Front dozer blade Rear outrigger	7.5	-	-	-	-	-	-	-	-	-	-	-	-	-	-	-	-	-	-	-	-	-	3.5	5.2*	5.2*	5.2*	6.1
	6	-	-	-	-	-	-	-	-	-	-	-	-	-	-	-	-	-	-	-	-	-	2.7	4.3	4.0	4.8*	7.3
	4.5	-	-	-	-	-	-	-	-	-	-	-	-	-	-	-	-	-	-	-	-	-	3.6	5.8	5.3	6.7*	8.0
	3	-	-	-	-	-	-	-	-	5.1	8.7	7.9	9.4*	3.4	5.6	5.1	7.5*	2.5	4.0	3.7	6.5*	2.1	3.4	3.1	4.8*	8.3	
	1.5	-	-	-	-	-	-	-	-	4.7	8.2	7.4	11.1*	3.2	5.4	4.9	8.3*	2.4	3.9	3.6	6.8*	2.0	3.3	3.0	5.1*	8.4	
	0	-	-	-	-	-	-	-	-	4.4	7.8	7.0	11.9*	3.0	5.2	4.7	8.7*	2.3	3.8	3.5	6.8	2.0	3.4	3.1	5.6*	8.2	
	-1.5	6.4*	6.4*	6.4*	6.4*	7.6	10.9*	10.9*	10.9*	4.3	7.7	6.9	11.5*	3.0	5.1	4.6	8.5*	2.2	3.8	3.4	6.4*	2.2	3.6	3.3	6*	7.7	
-3	-	-	-	-	7.6	13.8*	13.8	13.8*	4.3	7.7	6.9	9.9*	3.0	5.1	4.6	7.2*	-	-	-	-	-	2.6	4.3	3.9	5.8*	6.8	
-4.5	-	-	-	-	-	-	-	-	4.4	6.6*	6.6*	6.6*	-	-	-	-	-	-	-	-	-	3.6	5.0*	5.0*	5.0*	5.3	
Mono Boom: 5m Dipper arm: 2.45m Rear dozer blade	7.5	-	-	-	-	-	-	-	-	-	-	-	-	-	-	-	-	-	-	-	-	-	4.0	4.5	5.3*	5.3*	5.2
	6	-	-	-	-	-	-	-	-	-	-	-	-	-	-	-	-	-	-	-	-	-	2.8	3.1	4.3	4.6*	6.5
	4.5	-	-	-	-	-	-	-	-	4.9	5.5	7.8	8.5*	3.1	3.5	4.9	7.1*	-	-	-	-	-	2.2	2.5	3.6	4.5*	7.3
	3	-	-	-	-	-	-	-	-	4.4	5.1	7.3	10.2*	3.0	3.3	4.7	7.6	2.1	2.4	3.3	5.2	2.0	2.3	3.2	4.5*	7.7	
	1.5	-	-	-	-	-	-	-	-	4.1	4.7	6.9	11.4*	2.8	3.2	4.5	7.3	2.0	2.3	3.3	5.1	1.9	2.2	3.1	4.8*	7.8	
	0	-	-	-	-	-	-	-	-	3.9	4.5	6.6	11.6*	2.6	3.0	4.4	7.2	2.0	2.2	3.2	5.1	1.9	2.2	3.2	5.0	7.5	
	-1.5	-	-	-	-	7.0	8.2	11.6*	11.6*	3.8	4.4	6.6	10.6*	2.6	3.0	4.3	7.1	-	-	-	-	-	2.1	2.4	3.5	5.6	7.0
-3	-	-	-	-	7.1	8.4	11.0*	11.0*	3.9	4.5	6.7	8.3*	-	-	-	-	-	-	-	-	-	2.7	3.1	4.4	5.5*	6.0	
Mono Boom: 5m Dipper arm: 2.6m Rear dozer blade	7.5	-	-	-	-	-	-	-	-	-	-	-	-	-	-	-	-	-	-	-	-	-	3.8	4.3	4.9*	4.9*	5.4
	6	-	-	-	-	-	-	-	-	-	-	-	-	-	-	-	-	-	-	-	-	-	2.6	3.0	4.2	4.4*	6.7
	4.5	-	-	-	-	-	-	-	-	4.9	5.5	7.8	8.2*	3.1	3.5	4.9	7*	-	-	-	-	-	2.2	2.4	3.4	4.2*	7.4
	3	-	-	-	-	-	-	-	-	4.5	5.1	7.3	10*	3.0	3.4	4.7	7.6	2.1	2.4	3.3	5.2	1.9	2.2	3.1	4.3*	7.8	
	1.5	-	-	-	-	-	-	-	-	4.1	4.7	6.9	11.3*	2.8	3.2	4.5	7.4	2.0	2.3	3.2	5.1	1.8	2.1	3.0	4.6*	7.9	
	0	-	-	-	-	5.9*	5.9*	5.9*	5.9*	3.9	4.5	6.6	11.6*	2.6	3.0	4.4	7.2	1.9	2.2	3.2	5.1	1.9	2.1	3.1	4.9	7.7	
	-1.5	-	-	-	-	6.9	8.2	11.3*	11.3*	3.8	4.4	6.6	10.7*	2.6	3.0	4.3	7.1	-	-	-	-	-	2.1	2.4	3.4	5.4	7.1
-3	-	-	-	-	7.1	8.3	11.5*	11.5*	3.9	4.5	6.6	8.6*	2.6	3.0	4.4	5.9*	-	-	-	-	-	2.6	2.9	4.2	5.5*	6.2	

Notes: 1. Working pressure with Power Boost = 37.5 MPa. 2. The above values are in compliance with ISO standard 10 567. They do not exceed 87 % of hydraulic lifting capacity or 75 % of tipping load, with the machine on firm, level ground. 3. Load capacities marked with an asterisk (*) are limited by machine's hydraulic lifting capacity rather than tipping load.

LIFTING CAPACITY EW180E

At the arm end, without bucket and quick fit. For lifting capacity including bucket/quick fit, simply subtract actual weight of those parts from the following values. With heavy counterweight. Unit: 1 000kg

	Lifting point	Reach from machine centre (u = support up/d = support down)																								
		1.5 m				3.0 m				4.5 m				6.0 m				7.5 m				Max.				
		Across UC		Along UC		Across UC		Along UC		Across UC		Along UC		Across UC		Along UC		Across UC		Along UC		Across UC		Along UC		Max.
		u	d	u	d	u	d	u	d	u	d	u	d	u	d	u	d	u	d	u	d	u	d	u	d	m
Mono Boom: 5m Dipper arm: 3m Rear dozer blade	6	-	-	-	-	-	-	-	-	-	-	-	-	3.3	3.7	5.1	6.2*	-	-	-	-	2.4	2.7	3.7*	3.7*	7.1
	4.5	-	-	-	-	-	-	-	-	5.0	5.6	7.3*	7.3*	3.2	3.6	5.0	6.6*	2.2	2.4	3.4	5.2*	2.0	2.2	3.2	3.6*	7.8
	3	-	-	-	-	-	-	-	-	4.6	5.2	7.4	9.4*	3.0	3.4	4.8	7.4*	2.1	2.4	3.4	5.2	1.8	2.0	2.9	3.6*	8.2
	1.5	-	-	-	-	-	-	-	-	4.1	4.7	6.9	11.0*	2.8	3.2	4.5	7.4	2.0	2.3	3.2	5.1	1.7	1.9	2.8	3.8*	8.3
	0	-	-	-	-	6.4*	6.4*	6.4*	6.4*	3.8	4.4	6.6	11.6*	2.6	3.0	4.4	7.2	1.9	2.2	3.2	5.0	1.7	2.0	2.8	4.2*	8.1
	-1.5	6.2*	6.2*	6.2*	6.2*	6.8	8.0	10.5*	10.5*	3.8	4.4	6.5	11.0*	2.5	2.9	4.3	7.1	1.9	2.2	3.1	5.0	1.9	2.1	3.1	5.0	7.6
-3	-	-	-	-	6.9	8.2	12.8*	12.8*	3.8	4.4	6.5	9.3*	2.6	2.9	4.3	6.7*	-	-	-	-	2.2	2.6	3.7	5.4*	6.7	
Mono Boom: 5m Grab arm: 3.2m Rear dozer blade	7.5	-	-	-	-	-	-	-	-	-	-	-	-	3.5	3.9	5.3	5.6*	-	-	-	-	3.4	3.8	5.1	5.2*	6.1
	6	-	-	-	-	-	-	-	-	-	-	-	-	3.5	3.9	5.3	6.3*	-	-	-	-	2.6	2.9	3.9	4.8*	7.3
	4.5	-	-	-	-	-	-	-	-	-	-	-	-	3.4	3.8	5.2	6.7*	2.4	2.7	3.7	5.6	2.2	2.4	3.3	4.7*	8.0
	3	-	-	-	-	-	-	-	-	4.9	5.5	7.8	9.4*	3.2	3.6	5.0	7.5*	2.3	2.6	3.6	5.5	2.0	2.2	3.1	4.6	8.3
	1.5	-	-	-	-	-	-	-	-	4.4	5.0	7.3	11.1*	3.0	3.4	4.8	7.6	2.2	2.5	3.5	5.4	1.9	2.1	3.0	4.5	8.4
	0	-	-	-	-	-	-	-	-	4.2	4.8	6.9	11.9*	2.9	3.3	4.6	7.4	2.2	2.4	3.4	5.3	1.9	2.2	3.0	4.6	8.2
-1.5	6.4*	6.4*	6.4*	6.4*	7.1	8.4	10.9*	10.9*	4.0	4.6	6.8	11.5*	2.8	3.2	4.5	7.3	2.1	2.4	3.4	5.2	2.0	2.3	3.3	5.0	7.7	
-3	-	-	-	-	7.2	8.5	13.5	13.8*	4.0	4.6	6.8	9.9*	2.8	3.2	4.5	7.2*	-	-	-	-	2.4	2.7	3.8	5.8*	6.8	
-4.5	-	-	-	-	-	-	-	-	4.2	4.8	6.6*	6.6*	-	-	-	-	-	-	-	-	3.4	3.8	5.0*	5.0*	5.3	
Mono Boom: 5m Dipper arm: 2.45m Front outrigger Rear dozer blade	7.5	-	-	-	-	-	-	-	-	-	-	-	-	3.4	5.5	4.8	6.8*	-	-	-	-	4.2	5.3*	5.3*	5.3*	5.2
	6	-	-	-	-	-	-	-	-	-	-	-	-	3.4	5.5	4.8	6.8*	-	-	-	-	2.9	4.6*	4.2	4.6*	6.5
	4.5	-	-	-	-	-	-	-	-	5.1	8.5*	7.6	8.5*	3.3	5.4	4.8	7.1*	-	-	-	-	2.4	3.9	3.4	4.5*	7.3
	3	-	-	-	-	-	-	-	-	4.7	8.1	7.1	10.2*	3.1	5.2	4.6	7.8*	2.2	3.7	3.2	6.2*	2.1	3.5	3.1	4.5*	7.7
	1.5	-	-	-	-	-	-	-	-	4.3	7.6	6.6	11.4*	2.9	5.0	4.4	8.4*	2.1	3.6	3.2	6.7*	2.0	3.4	3.0	4.8*	7.8
	0	-	-	-	-	-	-	-	-	4.1	7.4	6.4	11.6*	2.8	4.8	4.2	8.5*	2.1	3.5	3.1	6.1*	2.1	3.5	3.1	5.4*	7.5
-1.5	-	-	-	-	7.4	11.6*	11.6*	11.6*	4.1	7.3	6.4	10.6*	2.8	4.8	4.2	7.8*	-	-	-	-	2.3	3.9	3.4	6.1*	7.0	
-3	-	-	-	-	7.6	11.0*	11.0*	11.0*	4.1	7.4	6.4	8.3*	-	-	-	-	-	-	-	-	2.9	4.9	4.3	5.5*	6.0	
Mono Boom: 5m Dipper arm: 2.6m Front outrigger Rear dozer blade	7.5	-	-	-	-	-	-	-	-	-	-	-	-	3.4	5.5	4.9	6.7*	-	-	-	-	4.0	4.9*	4.9*	4.9*	5.4
	6	-	-	-	-	-	-	-	-	-	-	-	-	3.4	5.5	4.9	6.7*	-	-	-	-	2.8	4.4*	4.0	4.4*	6.7
	4.5	-	-	-	-	-	-	-	-	5.2	8.2*	7.6	8.2*	3.3	5.4	4.8	7.0*	-	-	-	-	2.3	3.8	3.3	4.2*	7.4
	3	-	-	-	-	-	-	-	-	4.7	8.1	7.1	10*	3.1	5.2	4.6	7.7*	2.2	3.7	3.2	6.5*	2.0	3.4	3.0	4.3*	7.8
	1.5	-	-	-	-	-	-	-	-	4.3	7.6	6.7	11.3*	2.9	5.0	4.4	8.3*	2.1	3.6	3.1	6.6*	2.0	3.3	2.9	4.6*	7.9
	0	-	-	-	-	5.9*	5.9*	5.9*	5.9*	4.1	7.4	6.4	11.6*	2.8	4.8	4.2	8.5*	2.1	3.5	3.1	6.4*	2.0	3.4	3.0	5.1*	7.7
-1.5	-	-	-	-	7.3	11.3*	11.3*	11.3*	4.0	7.3	6.3	10.7*	2.8	4.8	4.2	7.9*	-	-	-	-	2.2	3.8	3.3	6*	7.1	
-3	-	-	-	-	7.5	11.5*	11.5*	11.5*	4.1	7.4	6.4	8.6*	2.8	4.8	4.2	5.9*	-	-	-	-	2.7	4.7	4.1	5.5*	6.2	
Mono Boom: 5m Dipper arm: 3m Front outrigger Rear dozer blade	7.5	-	-	-	-	-	-	-	-	-	-	-	-	3.4	5.5	4.9	6.2*	-	-	-	-	3.4	4.1*	4.1*	4.1*	6.0
	6	-	-	-	-	-	-	-	-	-	-	-	-	3.4	5.5	4.9	6.2*	-	-	-	-	2.5	3.7*	3.6	3.7*	7.1
	4.5	-	-	-	-	-	-	-	-	5.2	7.3*	7.3*	7.3*	3.3	5.4	4.8	6.6*	2.3	3.8	3.3	5.2*	2.1	3.5	3.1	3.6*	7.8
	3	-	-	-	-	-	-	-	-	4.8	8.2	7.2	9.4*	3.2	5.2	4.6	7.4*	2.2	3.7	3.2	6.3*	1.9	3.2	2.8	3.6*	8.2
	1.5	-	-	-	-	-	-	-	-	4.4	7.7	6.7	11.0*	2.9	5.0	4.4	8.1*	2.1	3.6	3.1	6.5*	1.8	3.1	2.7	3.8*	8.3
	0	-	-	-	-	6.4*	6.4*	6.4*	6.4*	4.1	7.4	6.4	11.6*	2.8	4.8	4.2	8.4*	2.0	3.5	3.0	6.5*	1.8	3.1	2.7	4.2*	8.1
-1.5	6.2*	6.2*	6.2*	6.2*	7.2	10.5*	10.5*	10.5*	4.0	7.2	6.3	11.0*	2.7	4.7	4.1	8.1*	2.0	3.5	3.0	5.7	2.0	3.4	3.0	5*	7.6	
-3	-	-	-	-	7.4	12.8*	12.8	12.8*	4.0	7.3	6.3	9.3*	2.7	4.7	4.1	6.7*	-	-	-	-	2.4	4.1	3.6	5.4*	6.7	
Mono Boom: 5m Grab arm: 3.2m Front outrigger Rear dozer blade	7.5	-	-	-	-	-	-	-	-	-	-	-	-	3.6	5.6*	5.1	5.6*	-	-	-	-	3.5	5.2*	5.0	5.2*	6.1
	6	-	-	-	-	-	-	-	-	-	-	-	-	3.7	5.8	5.2	6.2*	-	-	-	-	2.7	4.2	3.8	4.8*	7.3
	4.5	-	-	-	-	-	-	-	-	-	-	-	-	3.6	5.7	5.0	6.7*	2.5	4.0	3.6	6.1*	2.3	3.6	3.2	4.7*	8.0
	3	-	-	-	-	-	-	-	-	5.1	8.5	7.5	9.4*	3.4	5.4	4.8	7.5*	2.4	3.9	3.5	6.4*	2.0	3.3	2.9	4.8*	8.3
	1.5	-	-	-	-	-	-	-	-	4.6	8.0	7.0	11.1*	3.2	5.2	4.6	8.2*	2.3	3.8	3.4	6.7*	2.0	3.2	2.8	5.1*	8.4
	0	-	-	-	-	-	-	-	-	4.3	7.6	6.7	11.8*	3.0	5.0	4.4	8.6*	2.2	3.7	3.3	6.8*	2.0	3.3	2.9	5.6*	8.2
-1.5	6.4*	6.4*	6.4*	6.4*	7.5	10.9*	10.9*	10.9*	4.2	7.5	6.5	11.4*	2.9	4.9	4.3	8.4*	2.2	3.7	3.2	6.3*	2.1	3.5	3.1	6*	7.7	
-3	-	-	-	-	7.6	13.8*	13.0	13.8*	4.2	7.5	6.5	9.9*	2.9	4.9	4.3	7.2*	-	-	-	-	2.5	4.2	3.7	5.8*	6.8	
-4.5	-	-	-	-	-	-	-	-	4.4	6.5*	6.5*	6.5*	-	-	-	-	-	-	-	-	3.5	5.0*	5.0*	5.0*	5.3	

Notes: 1. Working pressure with Power Boost = 37.5 MPa. 2. The above values are in compliance with ISO standard 10 567. They do not exceed 87 % of hydraulic lifting capacity or 75 % of tipping load, with the machine on firm, level ground. 3. Load capacities marked with an asterisk (*) are limited by machine's hydraulic lifting capacity rather than tipping load.

Specifications

EW180E

LIFTING CAPACITY EW180E

At the arm end, without bucket and quick fit. For lifting capacity including bucket/quick fit, simply subtract actual weight of those parts from the following values. With heavy counterweight. Unit: 1 000kg

	Lifting point	Reach from machine centre (u = support up/d = support down)																												
		1.5 m				3.0 m				4.5 m				6.0 m				7.5 m				Max.								
		Across UC		Along UC		Across UC		Along UC		Across UC		Along UC		Across UC		Along UC		Across UC		Along UC		Max.								
		u	d	u	d	u	d	u	d	u	d	u	d	u	d	u	d	u	d	u	d	m								
Mono Boom: 5m Dipper arm: 2.45m Front and rear outriggers	6	-	-	-	-	-	-	-	-	-	-	-	-	3.4	6.8*	5.0	6.8*	-	-	-	-	3.0	4.6*	4.3	4.6*	6.5				
	4.5	-	-	-	-	-	-	-	-	5.2	8.5*	7.8	8.5*	3.3	6.8	4.9	7.1*	-	-	-	-	2.4	4.5*	3.6	4.5*	7.3				
	3	-	-	-	-	-	-	-	-	4.8	10.2*	7.4	10.2*	3.2	6.6	4.7	7.8*	2.2	4.6	3.4	6.2*	2.2	4.4	3.2	4.5*	7.7				
	1.5	-	-	-	-	-	-	-	-	4.4	10.1	6.9	11.4*	3.0	6.4	4.6	8.4*	2.2	4.6	3.3	6.7*	2.0	4.3	3.1	4.8*	7.8				
	0	-	-	-	-	-	-	-	-	4.2	9.8	6.7	11.6*	2.9	6.2	4.4	8.5*	2.1	4.5	3.2	6.1*	2.1	4.4	3.2	5.4*	7.5				
	-1.5	-	-	-	-	-	7.5	11.6*	11.6*	11.6*	4.1	9.7	6.6	10.6*	2.8	6.2	4.4	7.8*	-	-	-	-	2.3	5.0	3.6	6.1*	7.0			
-3	-	-	-	-	-	7.7	11.0*	11.0*	11.0*	4.2	8.3*	6.7	8.3*	-	-	-	-	-	-	-	-	2.9	5.5*	4.5	5.5*	6.0				
Mono Boom: 5m Dipper arm: 2.6m Front and rear outriggers	7.5	-	-	-	-	-	-	-	-	-	-	-	-	-	-	-	-	-	-	-	-	-	-	-	-	4.0	4.9*	4.9*	4.9*	5.4
	6	-	-	-	-	-	-	-	-	-	-	-	-	3.4	6.7*	5.0	6.7*	-	-	-	-	2.8	4.4*	4.2	4.4*	6.7				
	4.5	-	-	-	-	-	-	-	-	5.2	8.2*	7.9	8.2*	3.4	6.8	5.0	7*	-	-	-	-	2.3	4.2*	3.5	4.2*	7.4				
	3	-	-	-	-	-	-	-	-	4.8	10*	7.4	10.0*	3.2	6.6	4.8	7.7*	2.2	4.6	3.4	6.5*	2.1	4.3*	3.1	4.3*	7.8				
	1.5	-	-	-	-	-	-	-	-	4.4	10.1	6.9	11.3*	3.0	6.4	4.6	8.3*	2.2	4.5	3.3	6.6*	2.0	4.2	3.0	4.6*	7.9				
	0	-	-	-	-	-	5.9*	5.9*	5.9*	5.9*	4.2	9.8	6.7	11.6*	2.8	6.2	4.4	8.5*	2.1	4.5	3.2	6.4*	2.0	4.3	3.1	5.1*	7.7			
-1.5	-	-	-	-	-	7.5	11.3*	11.3*	11.3*	4.1	9.7	6.6	10.7*	2.8	6.2	4.3	7.9*	-	-	-	-	2.2	4.8	3.4	6*	7.1				
-3	-	-	-	-	-	7.6	11.5*	11.5*	11.5*	4.2	8.6*	6.7	8.6*	2.9	5.9*	4.4	5.9*	-	-	-	-	2.8	5.5*	4.3	5.5*	6.2				
Mono Boom: 5m Dipper arm: 3m Front and rear outriggers	7.5	-	-	-	-	-	-	-	-	-	-	-	-	-	-	-	-	-	-	-	-	-	-	-	-	3.5	4.1*	4.1*	4.1*	6.0
	6	-	-	-	-	-	-	-	-	-	-	-	-	3.5	6.2*	5.1	6.2*	-	-	-	-	2.6	3.7*	3.7*	3.7*	7.1				
	4.5	-	-	-	-	-	-	-	-	5.3	7.3*	7.3*	7.3*	3.4	6.6*	5.0	6.6*	2.3	4.7	3.4	5.2*	2.1	3.6*	3.2	3.6*	7.8				
	3	-	-	-	-	-	-	-	-	4.9	9.4*	7.5	9.4*	3.2	6.6	4.8	7.4*	2.2	4.6	3.4	6.3*	1.9	3.6*	2.9	3.6*	8.2				
	1.5	-	-	-	-	-	-	-	-	4.4	10.1	7.0	11.0*	3.0	6.4	4.6	8.1*	2.2	4.5	3.3	6.5*	1.8	3.8*	2.8	3.8*	8.3				
	0	-	-	-	-	-	6.4*	6.4*	6.4*	6.4*	4.2	9.8	6.7	11.6*	2.8	6.2	4.4	8.4*	2.1	4.4	3.2	6.5*	1.9	4.0	2.9	4.2*	8.1			
-1.5	6.2*	6.2*	6.2*	6.2*	6.2*	7.3	10.5*	10.5*	10.5*	4.1	9.7	6.6	11.0*	2.8	6.1	4.3	8.1*	2.0	4.4	3.2	5.7	2.0	4.4	3.1	5*	7.6				
-3	-	-	-	-	-	7.5	12.8*	12.8*	12.8*	4.1	9.3*	6.6	9.3*	2.8	6.1	4.3	6.7*	-	-	-	-	2.4	5.3	3.8	5.4*	6.7				
Mono Boom: 5m Grab arm: 3.2m Front and rear outriggers	7.5	-	-	-	-	-	-	-	-	-	-	-	-	3.7	5.6*	5.3	5.6*	-	-	-	-	3.6	5.2*	5.2	5.2*	6.1				
	6	-	-	-	-	-	-	-	-	-	-	-	-	3.8	6.3*	5.4	6.3*	-	-	-	-	2.7	4.8*	3.9	4.8*	7.3				
	4.5	-	-	-	-	-	-	-	-	-	-	-	-	3.6	6.7*	5.2	6.7*	2.6	5.0	3.7	6.2*	2.3	4.5	3.4	4.7*	8.0				
	3	-	-	-	-	-	-	-	-	5.2	9.4*	7.8	9.4*	3.5	6.9	5.0	7.5*	2.5	4.9	3.6	6.5*	2.1	4.2	3.1	4.8*	8.3				
	1.5	-	-	-	-	-	-	-	-	4.8	10.5	7.3	11.1*	3.3	6.7	4.8	8.3*	2.4	4.8	3.5	6.8*	2.0	4.0	3.0	5.1*	8.4				
	0	-	-	-	-	-	-	-	-	4.5	10.1	7.0	11.9*	3.1	6.5	4.6	8.7*	2.3	4.7	3.4	6.8*	2.1	4.1	3.0	5.6*	8.2				
-1.5	6.4*	6.4*	6.4*	6.4*	6.4*	7.7	10.9*	10.9*	10.9*	4.4	10.0	6.8	11.5*	3.0	6.4	4.6	8.5*	2.3	4.6	3.4	6.4*	2.2	4.5	3.3	6*	7.7				
-3	-	-	-	-	-	7.8	13.8*	13.6	13.8*	4.4	9.9*	6.8	9.9*	3.0	6.4	4.6	7.2*	-	-	-	-	2.6	5.3	3.9	5.8*	6.8				
-4.5	-	-	-	-	-	-	-	-	-	4.5	6.6*	6.6*	6.6*	-	-	-	-	-	-	-	-	3.6	5.0*	5.0*	5.0*	5.3				

Notes: 1. Working pressure with Power Boost = 37.5 MPa. 2. The above values are in compliance with ISO standard 10 567. They do not exceed 87 % of hydraulic lifting capacity or 75 % of tipping load, with the machine on firm, level ground. 3. Load capacities marked with an asterisk (*) are limited by machine's hydraulic lifting capacity rather than tipping load.

LIFTING CAPACITY EW180E

At the arm end, without bucket and quick fit. For lifting capacity including bucket/quick fit, simply subtract actual weight of those parts from the following values. With heavy counterweight. Unit: 1 000kg

	Lifting point	Reach from machine centre (u = support up/d = support down)																											
		1.5 m				3.0 m				4.5 m				6.0 m				7.5 m			Max.								
		Across UC		Along UC		Across UC		Along UC		Across UC		Along UC		Across UC		Along UC		Across UC		Along UC		Max.							
		u	d	u	d	u	d	u	d	u	d	u	d	u	d	u	d	u	d	u	d	m							
2-piece Boom: 5.47m Dipper Arm: 2.45m Front and rear outriggers	9	-	-	-	-	-	-	-	-	-	-	-	-	-	-	-	-	-	-	-	7.7*	7.7*	7.7*	3.5					
	7.5	-	-	-	-	-	-	-	-	5.6	6.9*	6.9*	6.9*	-	-	-	-	-	-	-	-	3.6	5.4*	5.4	5.4*	5.8			
	6	-	-	-	-	-	-	-	-	5.5	7.1*	7.1*	7.1*	3.5	6.4*	5.1	6.4*	-	-	-	-	2.6	4.8*	3.9	4.8*	7.0			
	4.5	-	-	-	-	-	-	-	-	5.2	8.2*	7.9	8.2*	3.4	6.8*	5.0	6.8*	2.3	4.8	3.5	6.1*	2.2	4.5*	3.3	4.5*	7.7			
	3	-	-	-	-	-	-	-	-	4.7	10*	7.4	10*	3.2	6.7	4.8	7.5*	2.2	4.7	3.4	6.3*	2.0	4.2	3.0	4.5*	8.1			
	1.5	-	-	-	-	-	-	-	-	4.3	10.1	6.9	11.2*	3.0	6.4	4.6	8.1*	2.2	4.6	3.3	6.5*	1.9	4.1	2.9	4.6*	8.2			
	0	-	-	-	-	-	-	-	-	4.1	9.9	6.7	11.4*	2.8	6.3	4.4	8.3*	2.1	4.5	3.2	6.4*	1.9	4.2	3.0	5*	7.9			
-1.5	-	-	-	-	-	-	-	-	4.1	9.8	6.6	10.6*	2.8	6.2	4.4	7.9*	-	-	-	-	2.1	4.6	3.3	5.7*	7.4				
2-piece Boom: 5.47m Dipper arm: 2.6m Front and rear outriggers	9	-	-	-	-	-	-	-	-	-	-	-	-	-	-	-	-	-	-	-	-	-	-	-	6.8	7.0*	7.0*	7.0*	3.9
	7.5	-	-	-	-	-	-	-	-	5.6	6.6*	6.6*	6.6*	-	-	-	-	-	-	-	-	3.4	5.1*	5.1*	5.1*	6.0			
	6	-	-	-	-	-	-	-	-	5.5	6.9*	6.9*	6.9*	3.5	6.3*	5.2	6.3*	-	-	-	-	2.5	4.5*	3.8	4.5*	7.1			
	4.5	-	-	-	-	-	-	-	-	5.2	8.0*	8.0	8.0*	3.4	6.7*	5.0	6.7*	2.3	4.8	3.5	6*	2.1	4.3*	3.2	4.3*	7.8			
	3	-	-	-	-	-	-	-	-	4.7	9.8*	7.4	9.8*	3.2	6.7	4.8	7.4*	2.2	4.7	3.4	6.2*	1.9	4.1	2.9	4.2*	8.2			
	1.5	-	-	-	-	-	-	-	-	4.3	10.2	6.9	11.1*	2.9	6.4	4.6	8.0*	2.1	4.6	3.3	6.5*	1.8	4.0	2.8	4.4*	8.3			
	0	-	-	-	-	-	-	-	-	4.1	9.9	6.7	11.4*	2.8	6.3	4.4	8.3*	2.1	4.5	3.2	6.4*	1.9	4.1	2.9	4.7*	8.1			
-1.5	-	-	-	-	-	-	-	-	4.0	9.8	6.6	10.7*	2.8	6.2	4.4	7.9*	2.1	4.5	3.2	5.7*	2.0	4.5	3.2	5.4*	7.6				
2-piece Boom: 5.47m Dipper Arm: 3m Front and rear outriggers	7.5	-	-	-	-	-	-	-	-	-	-	-	-	3.5	5.8*	5.2	5.8*	-	-	-	-	3.0	4.2*	4.2*	4.2*	6.5			
	6	-	-	-	-	-	-	-	-	5.6	5.8*	5.8*	5.8*	3.5	5.8*	5.2	5.8*	2.4	4.4*	3.5	4.4*	2.3	3.8*	3.4	3.8*	7.6			
	4.5	-	-	-	-	5.8*	5.8*	5.8*	5.8*	5.3	6.8*	6.8*	6.8*	3.4	6.3*	5.1	6.3*	2.3	4.8	3.5	5.7*	1.9	3.6*	3.0	3.6*	8.3			
	3	-	-	-	-	-	-	-	-	4.8	9.2*	7.5	9.2*	3.2	6.7	4.8	7.1*	2.2	4.7	3.4	6.0*	1.8	3.6*	2.7	3.6*	8.6			
	1.5	-	-	-	-	-	-	-	-	4.4	10.2	7.0	10.8*	3.0	6.5	4.6	7.8*	2.1	4.6	3.3	6.3*	1.7	3.7	2.6	3.7*	8.7			
	0	-	-	-	-	-	-	-	-	4.1	9.9	6.7	11.4*	2.8	6.3	4.4	8.2*	2.0	4.5	3.2	6.4	1.7	3.8	2.7	4.0*	8.5			
	-1.5	-	-	-	-	7.3*	7.6*	7.6*	7.6*	4.0	9.8	6.6	10.9*	2.7	6.2	4.3	8.0*	2.0	4.5	3.2	6.1	1.9	4.1	2.9	4.5*	8.0			
-3	-	-	-	-	-	-	-	-	4.0	9.5	6.6	9.5	2.7	6.2	4.3	7.0*	-	-	-	-	2.4	5.2	3.7	5.8	6.7				
2-piece Boom: 5.47m Grab arm: 3.2m Front and rear outriggers	9	-	-	-	-	-	-	-	-	5.8	6.9*	6.9*	6.9*	-	-	-	-	-	-	-	-	5.0	6.5*	6.5*	6.5*	4.9			
	7.5	-	-	-	-	-	-	-	-	-	-	-	-	3.8	6.0*	5.5	6.0*	-	-	-	-	3.1	5.3*	4.5	5.3*	6.7			
	6	-	-	-	-	-	-	-	-	-	-	-	-	3.8	5.9*	5.5	5.9*	2.6	5.1	3.8	5.8*	2.5	4.8	3.6	4.9*	7.8			
	4.5	-	-	-	-	-	-	-	-	5.6	6.6*	6.6*	6.6*	3.7	6.4*	5.3	6.4*	2.6	5.1	3.8	5.9*	2.1	4.2	3.1	4.7*	8.4			
	3	-	-	-	-	-	-	-	-	5.1	9.3*	7.8	9.3*	3.4	7.0	5.1	7.2*	2.5	5.0	3.7	6.2*	2.0	3.9	2.9	4.7*	8.8			
	1.5	-	-	-	-	-	-	-	-	4.4	10.2	7.0	11.7*	-	3.2	6.7	4.8	8*	2.4	4.9	3.6	6.6*	1.9	3.8	2.8	4.9*	8.8		
	0	-	-	-	-	-	-	-	-	4.4	10.2	7.0	11.7*	3.0	6.5	4.7	8.5*	2.3	4.8	3.4	6.7*	1.9	3.9	2.8	5.3*	8.6			
-1.5	-	-	-	-	7.6	7.9*	7.9*	7.9*	4.3	10.0	6.8	11.4*	3.0	6.4	4.6	8.4*	2.2	4.7	3.4	6.5*	2.0	4.2	3.1	5.6*	8.1				
-3	-	-	-	-	-	-	-	-	4.3	10.1	6.9	10.1*	3.0	6.4	4.6	7.5*	-	-	-	-	2.4	5.1	3.7	5.8*	7.1				
2-piece Boom: 5.47m Dipper Arm: 2.45m Front dozer blade Rear outriggers	9	-	-	-	-	-	-	-	-	-	-	-	-	-	-	-	-	-	-	-	-	-	-	-	7.7*	7.7*	7.7*	7.7*	3.5
	7.5	-	-	-	-	-	-	-	-	5.5	6.9*	6.9*	6.9*	-	-	-	-	-	-	-	-	-	-	-	3.6	5.4*	5.4*	5.4*	5.8
	6	-	-	-	-	-	-	-	-	5.4	7.1*	7.1*	7.1*	3.4	5.7	5.2	6.4*	-	-	-	-	2.6	4.4	4.0	4.8*	7.0			
	4.5	-	-	-	-	-	-	-	-	5.1	8.2*	8.0	8.2*	3.3	5.6	5.1	6.8*	2.3	3.9	3.5	6.1*	2.2	3.7	3.4	4.5*	7.7			
	3	-	-	-	-	-	-	-	-	4.6	8.3	7.4	10.0*	3.1	5.3	4.8	7.5*	2.2	3.8	3.4	6.3*	1.9	3.4	3.0	4.5*	8.1			
	1.5	-	-	-	-	-	-	-	-	4.2	7.8	7.0	11.2*	2.9	5.1	4.6	8.1*	2.1	3.7	3.3	6.5*	1.8	3.3	3.0	4.6*	8.2			
	0	-	-	-	-	-	-	-	-	4.0	7.6	6.8	11.4*	2.8	5.0	4.5	8.3*	2.0	3.6	3.3	6.4*	1.9	3.4	3.0	5.0*	7.9			
-1.5	-	-	-	-	-	-	-	-	4.0	7.5	6.7	10.6*	2.7	4.9	4.4	7.9*	-	-	-	-	2.1	3.7	3.3	5.7*	7.4				
2-piece Boom: 5.47m Dipper Arm: 2.6m Front dozer blade Rear outriggers	9	-	-	-	-	-	-	-	-	-	-	-	-	-	-	-	-	-	-	-	-	-	-	-	6.8	7.0*	7.0*	7.0*	3.9
	7.5	-	-	-	-	-	-	-	-	5.6	6.6*	6.6*	6.6*	-	-	-	-	-	-	-	-	-	-	-	3.4	5.1*	5.1*	5.1*	6.0
	6	-	-	-	-	-	-	-	-	5.5	6.9*	6.9*	6.9*	3.4	5.7	5.2	6.3*	-	-	-	-	2.5	4.2	3.8	4.5*	7.1			
	4.5	-	-	-	-	-	-	-	-	5.2	8.0*	8.0	8*	3.3	5.6	5.1	6.7*	2.3	3.9	3.5	6*	2.1	3.6	3.2	4.3*	7.8			
	3	-	-	-	-	-	-	-	-	4.7	8.3	7.5	9.8*	3.1	5.3	4.8	7.4*	2.2	3.8	3.4	6.2*	1.9	3.3	3.0	4.2*	8.2			
	1.5	-	-	-	-	-	-	-	-	4.2	7.8	7.0	11.1*	2.9	5.1	4.6	8.0*	2.1	3.7	3.3	6.5*	1.8	3.2	2.9	4.4*	8.3			
	0	-	-	-	-	-	-	-	-	4.0	7.6	6.8	11.4*	2.8	4.9	4.5	8.3*	2.0	3.6	3.3	6.4*	1.8	3.2	2.9	4.7*	8.1			
-1.5	-	-	-	-	-	-	-	-	4.0	7.5	6.7	10.7*	2.7	4.9	4.4	7.9*	2.0	3.6	3.3	5.7*	2.0	3.6	3.2	5.4*	7.6				

Notes: 1. Working pressure with Power Boost = 37.5 MPa. 2. The above values are in compliance with ISO standard 10 567. They do not exceed 87 % of hydraulic lifting capacity or 75 % of tipping load, with the machine on firm, level ground. 3. Load capacities marked with an asterisk (*) are limited by machine's hydraulic lifting capacity rather than tipping load.

Specifications

EW180E

LIFTING CAPACITY EW180E

At the arm end, without bucket and quick fit. For lifting capacity including bucket/quick fit, simply subtract actual weight of those parts from the following values. With heavy counterweight. Unit: 1 000kg

	Lifting point	Reach from machine centre (u = support up/d = support down)																									
		1.5 m			3.0 m			4.5 m			6.0 m			7.5 m			Max.										
		Across UC		Along UC	Across UC		Along UC	Across UC		Along UC	Across UC		Along UC	Across UC		Along UC	Across UC		Along UC	Max.							
		u	d	u	d	u	d	u	d	u	d	u	d	u	d	u	d	u	d	u	d	m					
2-piece Boom: 5.47m Dipper Arm: 3m Front dozer blade Rear outriggers	9	-	-	-	-	-	-	-	-	5.4	6.1*	6.1*	6.1*	-	-	-	-	-	-	-	5.0	5.4*	5.4*	5.4*	4.7		
	7.5	-	-	-	-	-	-	-	-	-	-	-	-	3.5	5.8	5.3	5.8*	-	-	-	-	3.0	4.2*	4.2*	4.2*	6.5	
	6	-	-	-	-	-	-	-	-	5.6	5.8*	5.8*	5.8*	3.5	5.8	5.3	5.8*	2.3	3.9	3.6	4.4*	2.2	3.8*	3.5	3.8*	7.6	
	4.5	-	-	-	-	5.8*	5.8*	5.8*	5.8*	5.2	6.8*	6.8*	6.8*	3.4	5.6	5.1	6.3*	2.3	3.9	3.6	5.7*	1.9	3.3	3.0	3.6*	8.3	
	3	-	-	-	-	-	-	-	-	4.8	8.4	7.6	9.2*	3.1	5.4	4.9	7.1*	2.2	3.8	3.4	6.0*	1.7	3.0	2.7	3.6*	8.6	
	1.5	-	-	-	-	-	-	-	-	4.3	7.9	7.0	10.8*	2.9	5.1	4.6	7.8*	2.1	3.7	3.3	6.3*	1.6	2.9	2.7	3.7*	8.7	
	0	-	-	-	-	-	-	-	-	4.0	7.6	6.7	11.4*	2.7	4.9	4.4	8.2*	2.0	3.6	3.2	6.4	1.7	3.0	2.7	4*	8.5	
	-1.5	-	-	-	-	7.1*	7.6*	7.6*	7.6*	3.9	7.4	6.6	10.9*	2.7	4.8	4.4	8*	2.0	3.5	3.2	6.1	1.8	3.3	3.0	4.5*	8.0	
-3	-	-	-	-	-	-	-	-	4.0	7.5	6.7	9.5*	2.7	4.9	4.4	7.0*	-	-	-	-	2.3	4.2	3.8	5.8*	6.7		
2-piece Boom: 5.47m Grab arm: 3.2m Front dozer blade Rear outriggers	9	-	-	-	-	-	-	-	-	5.7	6.9*	6.9*	6.9*	-	-	-	-	-	-	-	-	4.9	6.5*	6.5*	6.5*	4.9	
	7.5	-	-	-	-	-	-	-	-	-	-	-	-	3.8	6*	5.5	6.0*	-	-	-	-	-	3.1	5.0	4.6	5.3*	6.7
	6	-	-	-	-	-	-	-	-	-	-	-	-	3.8	5.9*	5.5	5.9*	2.6	4.2	3.8	5.8*	2.4	4.0	3.6	4.9*	7.8	
	4.5	-	-	-	-	-	-	-	-	5.5	6.6*	6.6*	6.6*	3.6	5.9	5.4	6.4*	2.6	4.2	3.8	5.9*	2.1	3.4	3.2	4.7*	8.4	
	3	-	-	-	-	-	-	-	-	5.1	8.8	7.9	9.3*	3.4	5.6	5.2	7.2*	2.5	4.0	3.7	6.2*	1.9	3.2	2.9	4.7*	8.8	
	1.5	-	-	-	-	-	-	-	-	-	-	-	-	3.2	5.4	4.9	8*	2.4	3.9	3.6	6.6*	1.8	3.1	2.8	4.9*	8.8	
	0	-	-	-	-	-	-	-	-	4.3	7.9	7.1	11.7*	3.0	5.2	4.7	8.5*	2.3	3.8	3.5	6.7*	1.9	3.2	2.9	5.3*	8.6	
	-1.5	-	-	-	-	7.4	7.9*	7.9*	7.9*	4.2	7.7	6.9	11.4*	2.9	5.1	4.6	8.4*	2.2	3.8	3.4	6.5*	2.0	3.4	3.1	5.6*	8.1	
-3	-	-	-	-	-	-	-	-	4.2	7.8	7.0	10.1*	2.9	5.1	4.6	7.5*	-	-	-	-	2.4	4.1	3.7	5.8*	7.1		
2-piece Boom: 5.47m Dipper Arm: 2.45m Rear dozer blade	7.5	-	-	-	-	-	-	-	-	5.3	5.9	6.9*	6.9*	-	-	-	-	-	-	-	-	-	3.4	3.9	5.4	5.4*	5.8
	6	-	-	-	-	-	-	-	-	5.2	5.9	7.1*	7.1*	3.2	3.7	5.1	6.4*	-	-	-	-	2.4	2.8	3.9	4.8*	7.0	
	4.5	-	-	-	-	-	-	-	-	4.9	5.5	7.9	8.2*	3.1	3.5	5.0	6.8*	2.1	2.4	3.4	5.4	2.0	2.3	3.3	4.5*	7.7	
	3	-	-	-	-	-	-	-	-	4.4	5.0	7.3	10*	2.9	3.3	4.8	7.5*	2.1	2.4	3.4	5.4	1.8	2.1	3.0	4.5*	8.1	
	1.5	-	-	-	-	-	-	-	-	4.0	4.6	6.9	11.2*	2.7	3.1	4.5	7.5	2.0	2.3	3.3	5.2	1.7	2.0	2.9	4.6	8.2	
	0	-	-	-	-	-	-	-	-	3.8	4.4	6.6	11.4*	2.6	3.0	4.4	7.3	1.9	2.2	3.2	5.2	1.8	2.0	3.0	4.8	7.9	
-1.5	-	-	-	-	-	-	-	-	3.8	4.4	6.6	10.6*	2.6	3.0	4.3	7.2	-	-	-	-	2.0	2.3	3.3	5.3	7.4		
2-piece Boom: 5.47m Dipper Arm: 2.6m Rear dozer blade	9	-	-	-	-	-	-	-	-	5.2	5.8	6.1*	6.1*	-	-	-	-	-	-	-	-	-	4.8	5.4*	5.4*	5.4*	4.7
	7.5	-	-	-	-	-	-	-	-	5.3	6.0	6.6*	6.6*	-	-	-	-	-	-	-	-	-	3.2	3.6	5.1*	5.1*	6.0
	6	-	-	-	-	-	-	-	-	5.2	5.9	6.9*	6.9*	3.3	3.7	5.1	6.3*	-	-	-	-	2.4	2.7	3.8	4.5*	7.1	
	4.5	-	-	-	-	-	-	-	-	4.9	5.6	7.9	8.0*	3.1	3.6	5.0	6.7*	2.1	2.4	3.5	5.4	2.0	2.2	3.2	4.3*	7.8	
	3	-	-	-	-	-	-	-	-	4.4	5.1	7.4	9.8*	2.9	3.3	4.8	7.4*	2.1	2.4	3.4	5.4	1.8	2.0	2.9	4.2*	8.2	
	1.5	-	-	-	-	-	-	-	-	4.0	4.6	6.9	11.1*	2.7	3.1	4.5	7.5	2.0	2.3	3.3	5.2	1.7	1.9	2.8	4.4*	8.3	
	0	-	-	-	-	-	-	-	-	3.8	4.4	6.6	11.4*	2.6	3.0	4.4	7.3	1.9	2.2	3.2	5.2	1.7	2.0	2.9	4.6	8.1	
-1.5	-	-	-	-	-	-	-	-	3.7	4.4	6.6	10.7*	2.5	2.9	4.3	7.2	1.9	2.2	3.2	5.2	1.9	2.2	3.2	5.1	7.6		
2-piece Boom: 5.47m Dipper Arm: 3m Rear dozer blade	9	-	-	-	-	-	-	-	-	5.2	5.8	6.1*	6.1*	-	-	-	-	-	-	-	-	-	4.8	5.4*	5.4*	5.4*	4.7
	7.5	-	-	-	-	-	-	-	-	-	-	-	-	3.3	3.7	5.2	5.8*	-	-	-	-	-	2.8	3.2	4.2*	4.2*	6.5
	6	-	-	-	-	-	-	-	-	5.3	5.8*	5.8*	5.8*	3.3	3.7	5.2	5.8*	2.2	2.5	3.5	4.4*	2.1	2.4	3.4	3.8*	7.6	
	4.5	-	-	-	-	5.8*	5.8*	5.8*	5.8*	5.0	5.7	6.8*	6.8*	3.2	3.6	5.0	6.3*	2.2	2.5	3.5	5.5	1.8	2.0	2.9	3.6*	8.3	
	3	-	-	-	-	-	-	-	-	4.5	5.2	7.5	9.2*	3.0	3.4	4.8	7.1*	2.1	2.4	3.4	5.4	1.6	1.8	2.7	3.6*	8.6	
	1.5	-	-	-	-	-	-	-	-	4.0	4.7	6.9	10.8*	2.7	3.1	4.5	7.5	2.0	2.3	3.3	5.2	1.5	1.8	2.6	3.7*	8.7	
	0	-	-	-	-	-	-	-	-	3.8	4.4	6.6	11.4*	2.6	3.0	4.4	7.3	1.9	2.2	3.2	5.1	1.6	1.8	2.7	4.0*	8.5	
	-1.5	-	-	-	-	6.7*	7.6*	7.6*	7.6*	3.7	4.3	6.5	10.9*	2.5	2.9	4.3	7.2	1.8	2.1	3.1	5.1	1.7	2.0	2.9	4.5*	8.0	
-3	-	-	-	-	-	-	-	-	3.7	4.3	6.6	9.5	2.5	2.9	4.3	7.0	-	-	-	-	2.2	2.5	3.7	5.8	6.7		
2-piece Boom: 5.47m Grab arm: 3.2m Rear dozer blade	9	-	-	-	-	-	-	-	-	5.5	6.2	6.9*	6.9*	-	-	-	-	-	-	-	-	-	4.7	5.2	6.5*	6.5*	4.9
	7.5	-	-	-	-	-	-	-	-	-	-	-	-	3.6	4.0	5.4	6*	-	-	-	-	-	2.9	3.3	4.5	5.3*	6.7
	6	-	-	-	-	-	-	-	-	-	-	-	-	3.6	4.0	5.4	5.9*	2.4	2.8	3.8	5.8	2.3	2.6	3.6	4.9*	7.8	
	4.5	-	-	-	-	-	-	-	-	5.3	6.0	6.6*	6.6*	3.4	3.9	5.3	6.4*	2.4	2.7	3.8	5.8	2.0	2.2	3.1	4.7*	8.4	
	3	-	-	-	-	-	-	-	-	4.8	5.5	7.8	9.3*	3.2	3.6	5.1	7.2*	2.3	2.6	3.6	5.6	1.8	2.0	2.9	4.4	8.8	
	1.5	-	-	-	-	-	-	-	-	-	-	-	-	3.0	3.4	4.8	7.8	2.2	2.5	3.5	5.5	1.7	2.0	2.8	4.3	8.8	
	0	-	-	-	-	-	-	-	-	4.1	4.7	6.9	11.7*	2.8	3.2	4.6	7.6	2.1	2.4	3.4	5.4	1.8	2.0	2.8	4.4	8.6	
-1.5	-	-	-	-	7.0	7.9*	7.9*	7.9*	4.0	4.6	6.8	11.4*	2.7	3.2	4.5	7.4	2.1	2.4	3.4	5.3	1.9	2.2	3.0	4.8	8.1		
-3	-	-	-	-	-	-	-	-	4.0	4.6	6.8	10.1*	2.8	3.2	4.5	7.4	-	-	-	-	2.2	2.6	3.6	5.8*	7.1		

Notes: 1. Working pressure with Power Boost = 37.5 MPa. 2. The above values are in compliance with ISO standard 10 567. They do not exceed 87 % of hydraulic lifting capacity or 75 % of tipping load, with the machine on firm, level ground. 3. Load capacities marked with an asterisk (*) are limited by machine's hydraulic lifting capacity rather than tipping load.

LIFTING CAPACITY EW180E

At the arm end, without bucket and quick fit. For lifting capacity including bucket/quick fit, simply subtract actual weight of those parts from the following values. With heavy counterweight. Unit: 1 000kg

	Lifting point	Reach from machine centre (u = support up/d = support down)																													
		1.5 m				3.0 m				4.5 m				6.0 m				7.5 m				Max.									
		Across UC		Along UC		Across UC		Along UC		Across UC		Along UC		Across UC		Along UC		Across UC		Along UC		Across UC	Along UC	Max.							
		u	d	u	d	u	d	u	d	u	d	u	d	u	d	u	d	u	d	u	d	u	d	m							
2-piece Boom: 5.47m Dipper Arm: 2.45m Front outrigger Rear dozer blade	9	-	-	-	-	-	-	-	-	-	-	-	-	-	-	-	-	-	-	-	-	-	7.7*	7.7*	7.7*	7.7*	3.5				
	7.5	-	-	-	-	-	-	-	-	5.5	6.9*	6.9*	6.9*	-	-	-	-	-	-	-	-	-	3.6	5.4*	5.2	5.4*	5.8				
	6	-	-	-	-	-	-	-	-	5.4	7.1*	7.1*	7.1*	3.4	5.6	5.0	6.4*	-	-	-	-	-	2.6	4.3	3.8	4.8*	7.0				
	4.5	-	-	-	-	-	-	-	-	5.1	8.3*	7.7	8.3*	3.3	5.4	4.8	6.8*	2.3	3.8	3.3	6.1*	2.2	3.6	3.2	4.5*	7.7					
	3	-	-	-	-	-	-	-	-	4.6	8.1	7.1	10.0*	3.1	5.2	4.6	7.5*	2.2	3.7	3.3	6.3*	1.9	3.3	2.9	4.5*	8.1					
	1.5	-	-	-	-	-	-	-	-	4.2	7.6	6.6	11.2*	2.9	5.0	4.4	8.1*	2.1	3.6	3.2	6.5*	1.9	3.2	2.8	4.6*	8.2					
	0	-	-	-	-	-	-	-	-	4.0	7.4	6.4	11.4*	2.8	4.8	4.2	8.3*	2.0	3.6	3.1	6.4*	1.9	3.3	2.9	5.0*	7.9					
	-1.5	-	-	-	-	-	-	-	4.0	7.4	6.4	10.6*	2.7	4.8	4.2	7.9*	-	-	-	-	-	2.1	3.6	3.2	5.7*	7.4					
2-piece Boom: 5.47m Dipper Arm: 2.6m Front outrigger Rear dozer blade	9	-	-	-	-	-	-	-	-	-	-	-	-	-	-	-	-	-	-	-	-	-	-	-	-	-	6.8	7.0*	7.0*	7.0*	3.9
	7.5	-	-	-	-	-	-	-	-	5.6	6.6*	6.6*	6.6*	-	-	-	-	-	-	-	-	-	3.4	5.1*	5.0	5.1*	6.0				
	6	-	-	-	-	-	-	-	-	5.5	6.9*	6.9*	6.9*	3.4	5.6	5.0	6.3*	-	-	-	-	-	2.5	4.1	3.7	4.5*	7.1				
	4.5	-	-	-	-	-	-	-	-	5.2	8.0*	7.7	8.0*	3.3	5.5	4.8	6.7*	2.3	3.8	3.4	6.0*	2.1	3.5	3.1	4.3*	7.8					
	3	-	-	-	-	-	-	-	-	4.7	8.1	7.2	9.8*	3.1	5.2	4.6	7.4*	2.2	3.7	3.3	6.2*	1.9	3.2	2.8	4.2*	8.2					
	1.5	-	-	-	-	-	-	-	-	4.2	7.6	6.7	11.1*	2.9	5.0	4.4	8.1*	2.1	3.6	3.2	6.5*	1.8	3.1	2.7	4.4*	8.3					
	0	-	-	-	-	-	-	-	-	4.0	7.4	6.4	11.4*	2.8	4.8	4.2	8.3*	2.0	3.5	3.1	6.5*	1.8	3.2	2.8	4.7*	8.1					
	-1.5	-	-	-	-	-	-	-	4.0	7.3	6.4	10.7*	2.7	4.8	4.2	7.9*	2.0	3.5	3.1	5.7*	2.0	3.5	3.1	5.4*	7.6						
2-piece Boom: 5.47m Dipper Arm: 3m Front outrigger Rear dozer blade	7.5	-	-	-	-	-	-	-	-	-	-	-	-	3.5	5.6	5.0	5.8*	-	-	-	-	-	3.0	4.2*	4.2*	4.2*	6.5				
	6	-	-	-	-	-	-	-	-	5.6	5.8*	5.8*	5.8*	3.5	5.7	5.0	5.8*	2.3	3.8	3.4	4.4*	2.2	3.8	3.3	3.8*	7.6					
	4.5	-	-	-	-	5.8*	5.8*	5.8*	5.8*	5.2	6.8*	6.8*	6.8*	3.4	5.5	4.9	6.3*	2.3	3.8	3.4	5.7*	1.9	3.2	2.8	3.6*	8.3					
	3	-	-	-	-	-	-	-	-	4.8	8.2	7.2	9.2*	3.1	5.3	4.6	7.1*	2.2	3.7	3.3	6.0*	1.7	3.0	2.6	3.6*	8.6					
	1.5	-	-	-	-	-	-	-	-	4.3	7.7	6.7	10.8*	2.9	5.0	4.4	7.8*	2.1	3.6	3.2	6.3*	1.6	2.9	2.5	3.7*	8.7					
	0	-	-	-	-	-	-	-	-	4.0	7.4	6.4	11.4*	2.7	4.8	4.2	8.2*	2.0	3.5	3.1	6.4	1.7	3.0	2.6	4*	8.5					
		-1.5	-	-	-	-	7.2*	7.6*	7.6*	7.6*	3.9	7.3	6.3	10.9*	2.7	4.7	4.1	8.1*	2.0	3.5	3.0	6.1	1.8	3.2	2.8	4.5*	8.0				
	-3	-	-	-	-	-	-	-	-	4.0	7.3	6.4	9.5	2.7	4.8	4.2	7.0*	-	-	-	-	-	2.3	4.1	3.6	5.8	6.7				
2-piece Boom: 5.47m Grab arm: 3.2m Front outrigger Rear dozer blade	9	-	-	-	-	-	-	-	-	5.7	6.8*	6.8*	6.8*	-	-	-	-	-	-	-	-	-	-	-	-	-	4.9	6.5*	6.5*	6.5*	4.9
	7.5	-	-	-	-	-	-	-	-	-	-	-	-	3.7	5.9	5.3	5.9*	-	-	-	-	-	3.1	4.9	4.4	5.3*	6.7				
	6	-	-	-	-	-	-	-	-	-	-	-	-	3.7	5.9	5.3	5.9*	2.6	4.1	3.6	5.8*	2.4	3.8	3.4	4.9*	7.8					
	4.5	-	-	-	-	-	-	-	-	5.5	6.6*	6.6*	6.6*	3.6	5.8	5.1	6.4*	2.5	4.1	3.6	5.8*	2.1	3.4	3.0	4.7*	8.4					
	3	-	-	-	-	-	-	-	-	5.0	8.5	7.5	9.2*	3.4	5.5	4.9	7.2*	2.4	4.0	3.5	6.2*	1.9	3.1	2.7	4.7*	8.8					
	1.5	-	-	-	-	-	-	-	-	-	-	-	-	3.1	5.2	4.6	8*	2.3	3.8	3.4	6.5*	1.8	3.0	2.7	4.9*	8.8					
	0	-	-	-	-	-	-	-	-	4.3	7.6	6.7	11.6*	3.0	5.1	4.4	8.5*	2.2	3.7	3.3	6.7*	1.8	3.1	2.7	5.2*	8.6					
	-1.5	-	-	-	-	7.4	7.8*	7.8*	7.8*	4.2	7.5	6.5	11.3*	2.9	5.0	4.4	8.4*	2.2	3.7	3.2	6.4*	2.0	3.3	2.9	5.6*	8.1					
	-3	-	-	-	-	-	-	-	-	4.2	7.5	6.6	10*	2.9	5.0	4.4	7.4*	-	-	-	-	-	2.4	4.0	3.5	5.7*	7.1				

Notes: 1. Working pressure with Power Boost = 37.5 MPa. 2. The above values are in compliance with ISO standard 10 567. They do not exceed 87 % of hydraulic lifting capacity or 75 % of tipping load, with the machine on firm, level ground. 3. Load capacities marked with an asterisk (*) are limited by machine's hydraulic lifting capacity rather than tipping load.

LIFTING CAPACITY EW220E (Off-road)

At the arm end, without bucket and quick fit. For lifting capacity including bucket/quick fit, simply subtract actual weight of those parts from the following values. With heavy counterweight. Unit: 1 000kg

	Lifting point	Reach from machine centre (u = support up/d = support down)																													
		3.0 m			4.5 m				6.0 m				7.5 m				9.0 m				Max.										
		Across UC		Along UC	Across UC		Along UC		Across UC		Along UC		Across UC		Along UC		Across UC		Along UC		Across UC	Along UC	Max.								
m	u	d	u	d	u	d	u	d	u	d	u	d	u	d	u	d	u	d	u	d	m										
Mono Boom: 5.7m Dipper arm: 2.45m Front and rear outriggers	7.5	-	-	-	-	-	-	-	-	-	-	-	-	-	-	-	-	-	-	-	-	4.2	5.9*	5.9*	5.9*	5.9					
	6	-	-	-	-	-	-	-	-	4.2	6.8*	6.1	6.8*	-	-	-	-	-	-	-	-	3.1	5.3*	4.6	5.3*	7.1					
	4.5	-	-	-	-	6.1	9.0	9.0	9.0	4.0	7.3	5.9	7.3	2.8	5.6	4.2	6.5	-	-	-	-	2.6	5.1	3.9	5.1	7.9					
	3	-	-	-	-	5.6	10.9	8.6	10.9	3.8	7.7	5.7	8.1	2.7	5.5	4.1	6.8	-	-	-	-	2.3	4.7	3.5	5.2	8.2					
	1.5	-	-	-	-	5.1	11.6	8.1	12.2	3.5	7.4	5.4	8.8	2.6	5.3	4.0	7.0	-	-	-	-	2.2	4.6	3.4	5.5	8.3					
	0	-	-	-	-	4.9	11.4	7.9	12.2	3.4	7.2	5.3	9.0	2.5	5.2	3.9	7.0	-	-	-	-	2.3	4.7	3.5	6.0	8.1					
	-3	8.9	10.6	10.6	10.6	4.9	11.3	7.9	11.3	3.3	7.2	5.2	8.5	2.5	5.2	3.9	6.2	-	-	-	-	2.5	5.2	3.8	6.1	7.6					
Mono Boom: 5.7m Dipper arm: 2.6m Front and rear outriggers	-3	9.1	11.9	11.9	11.9	5.0	9.4	8.0	9.4	3.4	7.0	5.3	7.0	-	-	-	-	-	-	-	-	3.0	5.7	4.6	5.7	6.7					
	7.5	-	-	-	-	-	-	-	-	-	-	-	-	-	-	-	-	-	-	-	-	-	-	-	-	4.0	5.5	5.5	5.5	6.1	
	6	-	-	-	-	-	-	-	-	-	-	-	-	-	-	-	-	-	-	-	-	-	-	-	-	3.0	5.0	4.4	5.0	7.3	
	4.5	-	-	-	-	6.1	8.8	8.8	8.8	4.0	7.2	6.0	7.2	2.8	5.6	4.2	6.4	-	-	-	-	2.5	4.8	3.8	4.8	8.0					
	3	-	-	-	-	5.6	10.7	8.7	10.7	3.8	7.7	5.7	8.0	2.7	5.5	4.1	6.7	-	-	-	-	2.3	4.6	3.5	4.8	8.4					
	1.5	-	-	-	-	5.1	11.6	8.2	12.1	3.5	7.4	5.4	8.7	2.6	5.3	4.0	6.9	-	-	-	-	2.2	4.5	3.3	5.1	8.5					
	0	-	-	-	-	4.9	11.4	7.9	12.2	3.4	7.2	5.3	8.9	2.5	5.2	3.9	7.0	-	-	-	-	2.2	4.6	3.4	5.6	8.3					
Mono Boom: 5.7m Dipper arm: 2.9m Front and rear outriggers	-1.5	8.8	10.4	10.4	10.4	4.9	11.3	7.9	11.4	3.3	7.2	5.2	8.5	2.5	5.2	3.9	6.4	-	-	-	-	2.4	5.0	3.7	6.0	7.7					
	-3	9.0	12.5	12.5	12.5	4.9	9.6	7.9	9.6	3.4	7.2	5.3	7.2	-	-	-	-	-	-	-	-	2.9	5.6	4.4	5.6	6.9					
	-4.5	-	-	-	-	5.2	6.3	6.3	6.3	-	-	-	-	-	-	-	-	-	-	-	-	-	-	-	-	4.3	5.2	5.2	5.2	5.1	
	7.5	-	-	-	-	-	-	-	-	-	-	-	-	-	-	-	-	-	-	-	-	-	-	-	-	-	3.6	4.8	4.8	4.8	6.5
	6	-	-	-	-	-	-	-	-	-	-	-	-	-	-	-	-	-	-	-	-	-	-	-	-	-	2.8	4.4	4.1	4.4	7.6
	4.5	-	-	-	-	6.2	8.3	8.3	8.3	4.0	6.9	6.0	6.3	2.9	5.4	4.3	5.4	-	-	-	-	2.4	4.2	3.6	4.2	8.3					
	3	-	-	-	-	5.7	10.3	8.8	10.3	3.8	7.7	5.7	7.8	2.7	5.5	4.1	6.5	-	-	-	-	2.1	4.3	3.3	4.3	8.7					
Mono Boom: 5.7m Dipper arm: 3.2m Front and rear outriggers	1.5	-	-	-	-	5.2	11.7	8.2	11.8	3.5	7.4	5.5	8.5	2.6	5.3	4.0	6.8	-	-	-	-	2.1	4.2	3.2	4.5	8.7					
	0	-	-	-	-	4.9	11.3	7.9	12.2	3.4	7.2	5.3	8.9	2.5	5.2	3.9	7.0	-	-	-	-	2.1	4.3	3.2	4.9	8.5					
	-1.5	8.7	10.0	10.0	10.0	4.8	11.2	7.8	11.6	3.3	7.1	5.2	8.6	2.5	5.2	3.8	6.6	-	-	-	-	2.2	4.7	3.5	5.6	8.1					
	-3	8.9	13.5	13.5	13.5	4.9	10.1	7.9	10.1	3.3	7.1	5.2	7.5	-	-	-	-	-	-	-	-	2.6	5.5	4.1	5.5	7.2					
	-4.5	-	-	-	-	5.0	7.1	7.1	7.1	-	-	-	-	-	-	-	-	-	-	-	-	-	-	-	-	-	3.6	4.7	4.7	4.7	5.9
	7.5	-	-	-	-	-	-	-	-	-	-	-	-	-	-	-	-	-	-	-	-	-	-	-	-	-	3.6	6.2	5.2	6.2	6.9
	6	-	-	-	-	-	-	-	-	-	-	-	-	-	-	-	-	-	-	-	-	-	-	-	-	-	2.8	5.4	4.1	5.8	7.9
Mono Boom: 5.7m Grab arm: 3.2m Front and rear outriggers	4.5	-	-	-	-	-	-	-	-	4.5	6.3	6.3	6.3	3.1	5.9	4.5	6.1	-	-	-	-	2.5	4.7	3.6	5.7	8.6					
	3	-	-	-	-	6.0	10.1	9.1	10.1	4.1	7.8	6.0	7.8	3.0	5.7	4.3	6.6	-	-	-	-	2.3	4.4	3.4	5.7	8.9					
	1.5	-	-	-	-	-	-	-	-	3.8	7.7	5.7	8.6	2.8	5.6	4.2	7.0	-	-	-	-	2.2	4.3	3.3	5.9	9.0					
	0	-	-	-	-	5.1	11.6	8.1	12.5	3.6	7.5	5.5	9.1	2.7	5.4	4.1	7.2	-	-	-	-	2.2	4.4	3.3	5.9	8.8					
	-1.5	8.8	9.9	9.9	9.9	5.0	11.4	8.0	12.1	3.5	7.3	5.4	9.0	2.7	5.4	4.0	7.0	-	-	-	-	2.3	4.7	3.5	5.9	8.3					
	-3	9.0	14.6	14.6	14.6	5.0	10.7	8.0	10.7	3.5	7.3	5.4	8.1	2.7	5.4	4.1	5.8	-	-	-	-	2.7	5.4	4.0	5.7	7.5					
	-4.5	9.3	10.7	10.7	10.7	5.2	8.1	8.1	8.1	3.6	5.7	5.5	5.7	-	-	-	-	-	-	-	-	3.5	5.2	5.2	5.2	6.3					
Mono Boom: 5.7m Dipper arm: 2.45m Front outrigger and Rear blade	7.5	-	-	-	-	-	-	-	-	-	-	-	-	-	-	-	-	-	-	-	-	-	-	-	-	4.1	5.9*	5.9*	5.9*	5.9	
	6	-	-	-	-	-	-	-	-	4.1	6.5	6.1	6.8*	-	-	-	-	-	-	-	-	3.0	4.9	4.6	5.3*	7.1					
	4.5	-	-	-	-	6.0	9.0	9.0	9.0	3.9	6.4	5.9	7.3	2.7	4.5	4.2	6.5	-	-	-	-	2.5	4.1	3.9	5.1	7.9					
	3	-	-	-	-	5.4	9.4	8.6	10.9	3.7	6.1	5.7	8.1	2.7	4.4	4.1	6.8	-	-	-	-	2.3	3.8	3.5	5.2	8.2					
	1.5	-	-	-	-	5.0	8.9	8.1	12.2	3.5	5.8	5.4	8.8	2.5	4.2	4.0	7.0	-	-	-	-	2.2	3.7	3.4	5.5	8.3					
	0	-	-	-	-	4.8	8.6	7.9	12.2	3.3	5.7	5.3	9.0	2.5	4.2	3.9	7.0	-	-	-	-	2.2	3.7	3.5	6.0	8.1					
	-3	8.7	10.6	10.6	10.6	4.8	8.6	7.9	11.3	3.3	5.6	5.2	8.5	2.5	4.2	3.9	6.2	-	-	-	-	2.4	4.1	3.8	6.1	7.6					
Mono Boom: 5.7m Dipper arm: 2.6m Front outrigger and Rear blade	-3	8.9	11.9	11.9	11.9	4.9	8.7	8.0	9.4	3.3	5.7	5.3	7.0	-	-	-	-	-	-	-	-	2.9	4.9	4.6	5.7	6.7					
	7.5	-	-	-	-	-	-	-	-	-	-	-	-	-	-	-	-	-	-	-	-	-	-	-	-	-	3.9	5.5	5.5	5.5	6.1
	6	-	-	-	-	-	-	-	-	-	-	-	-	-	-	-	-	-	-	-	-	-	-	-	-	-	2.9	4.7	4.4	5.0	7.3
	4.5	-	-	-	-	6.0	8.8	8.8	8.8	3.9	6.4	5.9	7.2	2.8	4.5	4.2	6.4	-	-	-	-	2.4	4.0	3.8	4.8	8.0					
	3	-	-	-	-	5.5	9.5	8.7	10.7	3.7	6.1	5.7	8.0	2.7	4.4	4.1	6.7	-	-	-	-	2.2	3.7	3.4	4.8	8.4					
	1.5	-	-	-	-	5.0	8.9	8.1	12.1	3.5	5.9	5.4	8.7	2.5	4.2	4.0	6.9	-	-	-	-	2.1	3.6	3.3	5.1	8.5					
	0	-	-	-	-	4.8	8.6	7.9	12.2	3.3	5.7	5.3	8.9	2.5	4.2	3.9	7.0	-	-	-	-	2.2	3.6	3.4	5.6	8.3					
Mono Boom: 5.7m Dipper arm: 2.9m Front outrigger and Rear blade	-1.5	8.6	10.4	10.4	10.4	4.7	8.6	7.8	11.4	3.2	5.6	5.2	8.5	2.4	4.1	3.8	6.4	-	-	-	-	2.3	4.0	3.7	6.0	7.7					
	-3	8.8	12.5	12.5	12.5	4.8	8.7	7.9	9.6	3.3	5.7	5.2	7.2	-	-	-	-	-	-	-	-	2.8	4.7	4.4	5.6	6.9					
	-4.5	-	-	-	-	5.0	6.3	6.3	6.3	-	-	-	-	-	-	-	-	-	-	-	-	-	-	-	-	-	4.2	5.2	5.2	5.2	5.1
	7.5	-	-	-	-	-	-	-	-	-	-	-	-	-	-	-	-	-	-	-	-	-	-	-	-	-	3.5	4.8	4.8	4.8	6.5
	6	-	-	-	-	-	-	-	-	-	-	-	-	-	-	-	-	-	-	-	-	-	-	-	-	-	2.7	4.4	4.1	4.4	7.6
	4.5	-	-	-	-	6.1	8.3	8.3	8.3	4.0	6.4	6.0	6.9	2.8	4.5	4.2	6.2	-	-	-	-	2.3	3.8	3.5	4.2	8.3					
	3	-	-	-	-	5.5	9.5	8.8	10.3	3.7	6.1	5.7	7.8	2.7	4.4	4.1	6.5	-	-	-	-	2.1	3.5	3.3	4.3	8.7					
Mono Boom: 5.7m Grab arm: 3.2m Front outrigger and Rear blade	1.5	-	-	-	-	5.0	8.9	8.2	11.8	3.5	5.9	5.4	8.5	2.5	4.2	4.0	6.8	-	-	-	-	2.0	3.4	3.2	4.5	8.7					
	0	-	-	-	-	4.8	8.6	7.9	12.2	3.3	5.7	5.2	8.9	2.4	4.1	3.9	7.0	-	-	-	-	2.0	3.4	3.2	4.9	8.5					
	-1.5	8.5	10.0	10.0	10.0	4.7	8.5	7.8	11.6	3.2	5.6	5.2	8.6	2.4	4.1	3.8	6.6	-	-	-	-	2.2	3.7	3.5	5.6	8.1					
	-3	8.7	13.5	13.5	13.5	4.7	8.6	7.8	10.1	3.2	5.6	5.2	7.5	-	-	-	-	-	-	-	-	2.6	4.4	4.1	5.5	7.2					
	-4																														

Specifications

EW220E

LIFTING CAPACITY EW220E (Off-road)

At the arm end, without bucket and quick fit. For lifting capacity including bucket/quick fit, simply subtract actual weight of those parts from the following values. With heavy counterweight. Unit: 1 000kg

	Lifting point	Reach from machine centre (u = support up/d = support down)																								
		3.0 m			4.5 m			6.0 m			7.5 m			9.0 m			Max.									
		Across UC	Along UC		Across UC	Along UC		Across UC	Along UC		Across UC	Along UC		Across UC	Along UC		Across UC	Along UC	Max.							
	m	u	d	u	d	u	d	u	d	u	d	u	d	u	d	u	d	u	d	m						
2-piece Boom: 5.72m Dipper arm: 2.45m Front and rear outriggers	9	-	-	-	-	-	-	-	-	-	-	-	-	-	-	-	-	-	-	-	7.8	8*	8*	8*	4.0	
	7.5	-	-	-	-	-	-	-	-	4.2	6.7*	6.2	6.7*	-	-	-	-	-	-	-	-	4.1	6*	6*	6*	6.1
	6	-	-	-	-	6.6	7.3	7.3	7.3	4.2	6.5	6.2	6.5	-	-	-	-	-	-	-	-	3.0	5.4	4.5	5.4	7.2
	4.5	-	-	-	-	6.2	8.6	8.6	8.6	4.0	7.0	6.1	7.0	2.8	5.7	4.3	6.3	-	-	-	-	2.5	5.1	3.9	5.1	7.9
	3	-	-	-	-	5.6	10.5	8.8	10.5	3.8	7.8	5.8	7.8	2.7	5.6	4.2	6.6	-	-	-	-	2.3	4.7	3.5	5.1	8.3
	1.5	-	-	-	-	5.1	11.8	8.2	11.9	3.5	7.5	5.5	8.5	2.6	5.4	4.0	6.8	-	-	-	-	2.2	4.6	3.4	5.3	8.4
	0	-	-	-	-	4.9	11.5	8.0	12.1	3.4	7.3	5.3	8.8	2.5	5.3	3.9	6.9	-	-	-	-	2.2	4.7	3.5	5.7	8.2
-1.5	8.8	9.3	9.3	9.3	4.8	11.3	7.9	11.3	3.3	7.3	5.3	8.5	2.5	5.3	3.9	6.3	-	-	-	-	2.4	5.1	3.8	6.0	7.7	
-3	-	-	-	-	4.9	9.7	8.0	9.7	3.4	7.2	5.3	7.2	-	-	-	-	-	-	-	-	3.0	6.1	4.7	6.1	6.6	
2-piece Boom: 5.72m Dipper arm: 2.6m Front and rear outriggers	9	-	-	-	-	-	-	-	-	-	-	-	-	-	-	-	-	-	-	-	-	6.9	7.3	7.3	7.3	4.3
	7.5	-	-	-	-	-	-	-	-	4.2	6.5	6.3	6.5	-	-	-	-	-	-	-	-	3.9	5.6	5.6	5.6	6.3
	6	-	-	-	-	-	-	-	-	4.2	6.4	6.3	6.4	-	-	-	-	-	-	-	-	2.9	5.0	4.4	5.0	7.4
	4.5	-	-	-	-	6.2	8.4	8.4	8.4	4.1	6.9	6.1	6.9	2.8	5.7	4.3	6.2	-	-	-	-	2.5	4.8	3.7	4.8	8.1
	3	-	-	-	-	5.6	10.3	8.8	10.3	3.8	7.7	5.8	7.7	2.7	5.6	4.2	6.5	-	-	-	-	2.2	4.6	3.4	4.8	8.5
	1.5	-	-	-	-	5.1	11.8	8.2	11.8	3.5	7.6	5.5	8.5	2.6	5.4	4.0	6.8	-	-	-	-	2.1	4.5	3.3	4.9	8.5
	0	-	-	-	-	4.9	11.5	8.0	12.1	3.4	7.3	5.3	8.8	2.5	5.3	3.9	6.9	-	-	-	-	2.2	4.6	3.4	5.3	8.3
-1.5	8.8	9.2	9.2	9.2	4.8	11.4	7.9	11.5	3.3	7.3	5.2	8.5	2.5	5.3	3.9	6.5	-	-	-	-	2.3	5.0	3.7	5.9	7.8	
-3	-	-	-	-	4.9	9.9	8.0	9.9	3.3	7.3	5.3	7.4	-	-	-	-	-	-	-	-	2.8	5.8	4.4	5.8	6.9	
2-piece Boom: 5.72m Dipper arm: 2.9m Front and rear outriggers	9	-	-	-	-	-	-	-	-	-	-	-	-	-	-	-	-	-	-	-	-	5.8	6.1	6.1	6.1	4.9
	7.5	-	-	-	-	-	-	-	-	4.3	6.1	6.1	6.1	-	-	-	-	-	-	-	-	3.5	4.9	4.9	4.9	6.7
	6	-	-	-	-	-	-	-	-	4.3	6.1	6.1	6.1	2.9	4.6	4.3	5.9	-	-	-	-	2.7	4.3	4.1	4.4	7.7
	4.5	-	-	-	-	6.3	8.0	8.0	8.0	4.1	6.5	6.1	6.6	2.9	4.6	4.3	5.9	-	-	-	-	2.3	3.8	3.5	4.2	8.4
	3	-	-	-	-	5.7	9.7	8.9	9.9	3.8	6.2	5.8	7.5	2.7	4.4	4.2	6.3	-	-	-	-	2.1	3.5	3.2	4.2	8.8
	1.5	-	-	-	-	5.2	9.0	8.3	11.5	3.5	5.9	5.5	8.3	2.6	4.3	4.0	6.7	-	-	-	-	2.0	3.3	3.1	4.3	8.8
	0	-	-	-	-	4.9	8.7	8.0	12.1	3.3	5.7	5.3	8.7	2.5	4.2	3.9	6.8	-	-	-	-	2.0	3.4	3.2	4.6	8.6
-1.5	8.6	8.9	8.9	8.9	4.8	8.6	7.9	11.6	3.3	5.6	5.2	8.6	2.4	4.1	3.8	6.6	-	-	-	-	2.2	3.7	3.5	5.2	8.2	
-3	-	-	-	-	4.8	8.6	7.9	10.3	3.3	5.6	5.2	7.7	-	-	-	-	-	-	-	-	2.6	4.3	4.0	5.4	7.3	
2-piece Boom: 5.72m Grab arm: 3.2m Front and rear outriggers	9	-	-	-	-	-	-	-	-	-	-	-	-	-	-	-	-	-	-	-	-	5.3	6.8	6.8	6.8	5.4
	7.5	-	-	-	-	-	-	-	-	4.6	5.9	5.9	5.9	-	-	-	-	-	-	-	-	3.5	6.1	5.1	6.1	7.0
	6	-	-	-	-	-	-	-	-	4.6	6.0	6.0	6.0	3.2	5.8	4.6	5.8	-	-	-	-	2.8	5.4	4.1	5.8	8.0
	4.5	-	-	-	-	6.7	7.8	7.8	7.8	4.4	6.6	6.4	6.6	3.1	6.0	4.6	6.0	-	-	-	-	2.4	4.7	3.6	5.6	8.7
	3	-	-	-	-	-	-	-	-	4.1	7.5	6.1	7.5	3.0	5.8	4.4	6.4	2.2	4.4	3.3	5.8	2.2	4.4	3.3	5.7	9.0
	1.5	-	-	-	-	-	-	-	-	3.8	7.8	5.8	8.4	2.8	5.7	4.2	6.8	2.2	4.3	3.3	5.8	2.1	4.3	3.2	5.8	9.1
	0	-	-	-	-	5.1	11.8	8.2	12.2	3.6	7.6	5.5	8.9	2.7	5.5	4.1	7.1	-	-	-	-	2.2	4.4	3.3	5.8	8.9
-1.5	-	-	-	-	5.0	11.6	8.1	12.0	3.5	7.4	5.4	8.9	2.6	5.4	4.0	6.9	-	-	-	-	2.3	4.7	3.5	5.8	8.4	
-3	8.9	15.1	15.1	15.1	5.0	10.9	8.1	10.9	3.5	7.4	5.4	8.2	2.7	5.5	4.1	5.9	-	-	-	-	2.6	5.3	4.0	5.6	7.6	
2-piece Boom: 5.72m Dipper arm: 2.45m Front outrigger and Rear blade	9	-	-	-	-	-	-	-	-	-	-	-	-	-	-	-	-	-	-	-	-	7.6	8*	8*	8*	4.0
	7.5	-	-	-	-	-	-	-	-	4.1	6.6	6.2	6.7*	-	-	-	-	-	-	-	-	4.0	6*	6*	6*	6.1
	6	-	-	-	-	6.5	7.3	7.3	7.3	4.1	6.5	6.2	6.5	-	-	-	-	-	-	-	-	3.0	4.9	4.5	5.4	7.2
	4.5	-	-	-	-	6.1	8.6	8.6	8.6	4.0	6.5	6.0	7.0	2.8	4.6	4.2	6.3	-	-	-	-	2.5	4.1	3.8	5.1	7.9
	3	-	-	-	-	5.5	9.6	8.8	10.5	3.7	6.2	5.8	7.8	2.7	4.4	4.1	6.6	-	-	-	-	2.2	3.8	3.5	5.1	8.3
	1.5	-	-	-	-	5.0	9.0	8.2	11.9	3.5	5.9	5.5	8.5	2.5	4.3	4.0	6.8	-	-	-	-	2.1	3.6	3.4	5.3	8.4
	0	-	-	-	-	4.8	8.7	7.9	12.1	3.3	5.7	5.3	8.8	2.4	4.2	3.9	6.9	-	-	-	-	2.2	3.7	3.5	5.7	8.2
-1.5	8.6	9.3	9.3	9.3	4.7	8.7	7.9	11.3	3.2	5.7	5.2	8.5	2.4	4.2	3.9	6.3	-	-	-	-	2.4	4.1	3.8	6.0	7.7	
-3	-	-	-	-	4.8	8.8	8.0	9.7	3.3	5.7	5.3	7.2	-	-	-	-	-	-	-	-	2.9	5.0	4.7	6.1	6.6	
2-piece Boom: 5.72m Dipper arm: 2.6m Front outrigger and Rear blade	9	-	-	-	-	-	-	-	-	-	-	-	-	-	-	-	-	-	-	-	-	6.8	7.3	7.3	7.3	4.3
	7.5	-	-	-	-	-	-	-	-	4.1	6.5	6.2	6.5	-	-	-	-	-	-	-	-	3.8	5.6	5.6	5.6	6.3
	6	-	-	-	-	-	-	-	-	4.2	6.4	6.3	6.4	-	-	-	-	-	-	-	-	2.8	4.7	4.4	5.0	7.4
	4.5	-	-	-	-	6.1	8.4	8.4	8.4	4.0	6.5	6.1	6.9	2.8	4.6	4.3	6.2	-	-	-	-	2.4	4.0	3.7	4.8	8.1
	3	-	-	-	-	5.5	9.6	8.8	10.3	3.7	6.2	5.8	7.7	2.7	4.4	4.1	6.5	-	-	-	-	2.2	3.7	3.4	4.8	8.5
	1.5	-	-	-	-	5.0	9.0	8.2	11.8	3.5	5.9	5.5	8.5	2.5	4.3	4.0	6.8	-	-	-	-	2.1	3.5	3.3	4.9	8.5
	0	-	-	-	-	4.8	8.7	7.9	12.1	3.3	5.7	5.3	8.8	2.4	4.2	3.9	6.9	-	-	-	-	2.1	3.6	3.4	5.3	8.3
-1.5	8.6	9.2	9.2	9.2	4.7	8.7	7.9	11.5	3.2	5.7	5.2	8.5	2.4	4.2	3.9	6.5	-	-	-	-	2.3	3.9	3.7	5.9	7.8	
-3	-	-	-	-	4.8	8.7	8.0	9.9	3.2	5.7	5.3	7.4	-	-	-	-	-	-	-	-	2.7	4.7	4.4	5.8	6.9	
2-piece Boom: 5.72m Dipper arm: 2.9m Front outrigger and Rear blade	9	-	-	-	-	-	-	-	-	-	-	-	-	-	-	-	-	-	-	-	-	5.7	6.1	6.1	6.1	4.9
	7.5	-	-	-	-	-	-	-	-	4.2	6.1	6.1	6.1	-	-	-	-	-	-	-	-	3.5	4.9	4.9	4.9	6.7
	6	-	-	-	-	-	-	-	-	4.2	6.1	6.1	6.1	2.8	4.6	4.3	5.9	-	-	-	-	2.6	4.4	4.1	4.4	7.7
	4.5	-	-	-	-	6.2	8.0	8.0	8.0	4.0	6.6	6.1	6.6	2.8	4.6	4.3	5.9	-	-	-	-	2.2	3.8	3.5	4.2	8.4
	3	-	-	-	-	5.6	9.7	8.9	9.9	3.7	6.3	5.8	7.5	2.7	4.5	4.2	6.3	-	-	-	-	2.0	3.5	3.2	4.2	8.8
	1.5	-	-	-	-	5.0	9.1	8.3	11.5	3.5	5.9	5.5	8.3	2.5	4.3	4.0	6.7	-	-	-	-	2.0	3.4	3.1	4.3	8.8
	0	-	-	-	-	4.8	8.7	7.9	12.1	3.3	5.7	5.3	8.7	2.4	4.2	3.9	6.8	-	-	-	-	2.0	3.4	3.2	4.6	8.6
-1.5	8.4	8.9	8.9	8.9	4.7	8.6	7.8	11.6	3.2	5.6	5.2	8.6	2.4	4.1	3.8	6.6	-	-	-	-	2.1	3.7	3.4	5.2	8.2	
-3	-	-	-	-	4.7	8.7	7.9	10.3	3.2	5.																

LIFTING CAPACITY EW220E (Off-road)

At the arm end, without bucket and quick fit. For lifting capacity including bucket/quick fit, simply subtract actual weight of those parts from the following values. With heavy counterweight. Unit: 1 000kg

	Lifting point	Reach from machine centre (u = support up/d = support down)																																																					
		3.0 m				4.5 m				6.0 m				7.5 m				9.0 m				Max.																																	
		Across UC		Along UC		Across UC		Along UC		Across UC		Along UC		Across UC		Along UC		Across UC		Along UC		Across UC	Along UC	Max.																															
m	u	d	u	d	u	d	u	d	u	d	u	d	u	d	u	d	u	d	u	d	u	d	m																																
2-piece Boom: 5.72m Dipper arm: 2.45m Rear blade only	9	-	-	-	-	-	-	-	-	-	-	-	-	-	-	-	-	-	-	-	-	-	-	7.3	8*	8*	8*	4.0																											
	7.5	-	-	-	-	-	-	-	-	3.9	4.6	5.9	6.7*	-	-	-	-	-	-	-	-	-	-	-	-	-	-	-	3.8	4.5	5.8	6*	6.1																						
	6	-	-	-	-	6.3	7.3	7.3	7.3	4.0	4.7	6.0	6.5	-	-	-	-	-	-	-	-	-	-	-	-	-	-	-	-	-	-	-	2.8	3.4	4.3	5.4	7.2																		
	4.5	-	-	-	-	5.8	7.0	8.6	8.6	3.8	4.5	5.8	7.0	2.6	3.1	4.1	6.3	-	-	-	-	-	-	-	-	-	-	-	-	-	-	-	-	-	-	2.3	2.8	3.7	5.1	7.9															
	3	-	-	-	-	5.2	6.3	8.4	10.5	3.5	4.2	5.5	7.8	2.5	3.0	3.9	6.6	-	-	-	-	-	-	-	-	-	-	-	-	-	-	-	-	-	-	-	2.1	2.5	3.3	5.1	8.3														
	1.5	-	-	-	-	4.7	5.8	7.8	11.9	3.3	4.0	5.2	8.5	2.4	2.9	3.8	6.8	-	-	-	-	-	-	-	-	-	-	-	-	-	-	-	-	-	-	-	-	2.0	2.4	3.2	5.3	8.4													
	0	-	-	-	-	4.5	5.6	7.6	12.1	3.1	3.8	5.1	8.8	2.3	2.8	3.7	6.9	-	-	-	-	-	-	-	-	-	-	-	-	-	-	-	-	-	-	-	-	-	2.0	2.5	3.3	5.7	8.2												
-1.5	8.2	9.3	9.3	9.3	4.5	5.5	7.5	11.3	3.0	3.7	5.0	8.5	2.3	2.8	3.7	6.3	-	-	-	-	-	-	-	-	-	-	-	-	-	-	-	-	-	-	-	-	-	-	2.2	2.7	3.6	6.0	7.7												
-3	-	-	-	-	4.6	5.6	7.6	9.7	3.1	3.8	5.0	7.2	-	-	-	-	-	-	-	-	-	-	-	-	-	-	-	-	-	-	-	-	-	-	-	-	-	-	-	2.8	3.3	4.4	6.1	6.6											
2-piece Boom: 5.72m Dipper arm: 2.6m Rear blade only	9	-	-	-	-	-	-	-	-	-	-	-	-	-	-	-	-	-	-	-	-	-	-	-	-	-	-	-	-	-	-	-	-	-	-	-	-	-	-	6.5	7.3	7.3	7.3	4.3											
	7.5	-	-	-	-	-	-	-	-	4.0	4.7	6.0	6.5	-	-	-	-	-	-	-	-	-	-	-	-	-	-	-	-	-	-	-	-	-	-	-	-	-	-	-	-	-	3.6	4.3	5.5	5.6	6.3								
	6	-	-	-	-	-	-	-	-	4.0	4.7	6.0	6.4	-	-	-	-	-	-	-	-	-	-	-	-	-	-	-	-	-	-	-	-	-	-	-	-	-	-	-	-	-	-	2.7	3.2	4.2	5.0	7.4							
	4.5	-	-	-	-	5.9	7.0	8.4	8.4	3.8	4.5	5.8	6.9	2.6	3.1	4.1	6.2	-	-	-	-	-	-	-	-	-	-	-	-	-	-	-	-	-	-	-	-	-	-	-	-	-	-	-	2.3	2.7	3.6	4.8	8.1						
	3	-	-	-	-	5.3	6.4	8.4	10.3	3.5	4.2	5.5	7.7	2.5	3.0	3.9	6.5	-	-	-	-	-	-	-	-	-	-	-	-	-	-	-	-	-	-	-	-	-	-	-	-	-	-	-	2.0	2.5	3.2	4.8	8.5						
	1.5	-	-	-	-	4.8	5.8	7.8	11.8	3.3	4.0	5.2	8.5	2.4	2.9	3.8	6.8	-	-	-	-	-	-	-	-	-	-	-	-	-	-	-	-	-	-	-	-	-	-	-	-	-	-	-	2.0	2.4	3.1	4.9	8.5						
	0	-	-	-	-	4.5	5.6	7.6	12.1	3.1	3.8	5.0	8.8	2.3	2.8	3.7	6.9	-	-	-	-	-	-	-	-	-	-	-	-	-	-	-	-	-	-	-	-	-	-	-	-	-	-	-	2.0	2.4	3.2	5.3	8.3						
-1.5	8.1	9.2	9.2	9.2	4.5	5.5	7.5	11.5	3.0	3.7	5.0	8.5	2.3	2.8	3.7	6.5	-	-	-	-	-	-	-	-	-	-	-	-	-	-	-	-	-	-	-	-	-	-	-	-	-	-	-	-	2.2	2.6	3.5	5.9	7.8						
-3	-	-	-	-	4.5	5.6	7.6	9.9	3.1	3.8	5.0	7.4	-	-	-	-	-	-	-	-	-	-	-	-	-	-	-	-	-	-	-	-	-	-	-	-	-	-	-	-	-	-	-	-	2.6	3.2	4.2	5.8	6.9						
2-piece Boom: 5.72m Dipper arm: 2.9m Rear blade only	9	-	-	-	-	-	-	-	-	-	-	-	-	-	-	-	-	-	-	-	-	-	-	-	-	-	-	-	-	-	-	-	-	-	-	-	-	-	-	-	-	-	-	-	-	-	5.4	6.1	6.1	6.1	4.9				
	7.5	-	-	-	-	-	-	-	-	4.0	4.8	6.1	6.1	-	-	-	-	-	-	-	-	-	-	-	-	-	-	-	-	-	-	-	-	-	-	-	-	-	-	-	-	-	-	-	-	-	-	-	3.3	3.9	4.9	4.9	6.7		
	6	-	-	-	-	-	-	-	-	4.0	4.7	6.1	6.1	2.7	3.2	4.1	5.9	-	-	-	-	-	-	-	-	-	-	-	-	-	-	-	-	-	-	-	-	-	-	-	-	-	-	-	-	-	-	-	2.5	3.0	3.9	4.4	7.7		
	4.5	-	-	-	-	6.0	7.1	8.0	8.0	3.8	4.6	5.9	6.6	2.7	3.2	4.1	5.9	-	-	-	-	-	-	-	-	-	-	-	-	-	-	-	-	-	-	-	-	-	-	-	-	-	-	-	-	-	-	-	-	2.1	2.6	3.4	4.2	8.4	
	3	-	-	-	-	5.3	6.5	8.5	9.9	3.6	4.3	5.6	7.5	2.5	3.0	4.0	6.3	-	-	-	-	-	-	-	-	-	-	-	-	-	-	-	-	-	-	-	-	-	-	-	-	-	-	-	-	-	-	-	1.9	2.3	3.1	4.2	8.8		
	1.5	-	-	-	-	4.8	5.9	7.9	11.5	3.3	4.0	5.3	8.3	2.4	2.9	3.8	6.7	-	-	-	-	-	-	-	-	-	-	-	-	-	-	-	-	-	-	-	-	-	-	-	-	-	-	-	-	-	-	-	1.8	2.2	3.0	4.3	8.8		
	0	-	-	-	-	4.5	5.6	7.6	12.1	3.1	3.8	5.0	8.7	2.3	2.8	3.7	6.8	-	-	-	-	-	-	-	-	-	-	-	-	-	-	-	-	-	-	-	-	-	-	-	-	-	-	-	-	-	-	-	1.9	2.3	3.0	4.6	8.6		
-1.5	8.0	8.9	8.9	8.9	4.4	5.5	7.5	11.6	3.0	3.7	4.9	8.6	2.2	2.7	3.6	6.6	-	-	-	-	-	-	-	-	-	-	-	-	-	-	-	-	-	-	-	-	-	-	-	-	-	-	-	-	-	-	-	-	2.0	2.5	3.3	5.2	8.2		
-3	-	-	-	-	4.5	5.5	7.5	10.3	3.0	3.7	4.9	7.7	-	-	-	-	-	-	-	-	-	-	-	-	-	-	-	-	-	-	-	-	-	-	-	-	-	-	-	-	-	-	-	-	-	-	-	2.4	2.9	3.8	5.4	7.3			
2-piece Boom: 5.72m Grab arm: 3.2m Rear blade only	9	-	-	-	-	-	-	-	-	-	-	-	-	-	-	-	-	-	-	-	-	-	-	-	-	-	-	-	-	-	-	-	-	-	-	-	-	-	-	-	-	-	-	-	-	-	-	-	-	5.0	5.8	6.8	6.8	5.4	
	7.5	-	-	-	-	-	-	-	-	4.3	5.1	5.9	5.9	-	-	-	-	-	-	-	-	-	-	-	-	-	-	-	-	-	-	-	-	-	-	-	-	-	-	-	-	-	-	-	-	-	-	-	-	-	3.3	3.8	4.9	6.1	7.0
	6	-	-	-	-	-	-	-	-	4.3	5.0	6.0	6.0	3.0	3.5	4.4	5.8	-	-	-	-	-	-	-	-	-	-	-	-	-	-	-	-	-	-	-	-	-	-	-	-	-	-	-	-	-	-	-	-	-	2.6	3.1	3.9	5.8	8.0
	4.5	-	-	-	-	6.3	7.5	7.8	7.8	4.1	4.8	6.1	6.6	2.9	3.4	4.4	6.0	-	-	-	-	-	-	-	-	-	-	-	-	-	-	-	-	-	-	-	-	-	-	-	-	-	-	-	-	-	-	-	-	-	2.2	2.7	3.4	5.6	8.7
	3	-	-	-	-	-	-	-	-	3.8	4.5	5.8	7.5	2.8	3.3	4.2	6.4	2.1	2.5	3.2	5.6	2.1	2.4	3.2	5.6	2.1	2.4	3.2	5.6	2.1	2.4	3.2	5.6	2.1	2.4	3.2	5.6	2.1	2.4	3.2	5.6	2.1	2.4	3.2	5.6	2.1	2.4	3.2	5.6	9.0					
	1.5	-	-	-	-	-	-	-	-	3.5	4.2	5.5	8.4	2.6	3.1	4.0	6.8	2.0	2.4	3.1	5.5	2.0	2.4	3.1	5.5	2.0	2.4	3.1	5.5	2.0	2.4	3.1	5.5	2.0	2.4	3.1	5.5	2.0	2.4	3.1	5.5	2.0	2.4	3.1	5.5	2.0	2.4	3.1	5.5	8.9					
	0	-	-	-	-	4.7	5.8	7.8	12.2	3.3	4.0	5.3	8.9	2.5	3.0	3.9	7.1	-	-	-	-	-	-	-	-	-	-	-	-	-	-	-	-	-	-	-	-	-	-	-	-	-	-	-	-	-	-	-	-	-	2.0	2.4	3.1	5.5	8.9
-1.5	-	-	-	-	4.6	5.7	7.7	12.0	3.2	3.9	5.1	8.9	2.4	2.9	3.8	6.9	-	-	-	-	-	-	-	-	-	-	-	-	-	-	-	-	-	-	-	-	-	-	-	-	-	-	-	-	-	-	-	-	-	2.1	2.5	3.3	5.8	8.4	
-3	8.3	10.6	15.1	15.1	4.6	5.7	7.7	10.9	3.2	3.9	5.1	8.2	2.5	3.0	3.9	5.9	-	-	-	-	-	-	-	-	-	-	-	-	-	-	-	-	-	-	-	-	-	-	-	-	-	-	-	-	-	-	-	-	2.4	2.9	3.8	5.6	7.6		

Notes: 1. Working pressure with Power Boost = 37.5 MPa. 2. The above values are in compliance with ISO standard 10 567. They do not exceed 87 % of hydraulic lifting capacity or 75 % of tipping load, with the machine on firm, level ground. 3. Load capacities marked with an asterisk (*) are limited by machine's hydraulic lifting capacity rather than tipping load.

Equipment

STANDARD EQUIPMENT

	EW180E	EW220E
Engine		
Turbocharged, 4 stroke Volvo diesel engine with water cooling, direct injection and charged air cooler that meets EU Stage V emission requirements	•	•
Intake air pre-heater	•	•
ECO Mode	•	•
Fuel filter and water separator	•	•
Fuel filler pump: 50 l/min with automatic shut-off	•	•
Aluminium core radiator	•	•
Electric / Electronic control system		
Contronics-computerized monitoring and diagnostic system	•	•
Adjustable automatic idling system	•	•
One-touch power boost	•	•
Adjustable monitor	•	•
Safety stop/start function and master electrical disconnect switch	•	•
2 Frame mounted halogen lamps	•	•
Alternator, 120 A	•	•
Batteries, 2 x 12 V/140 Ah	•	•
Start motor, 24 V/5.5 kW	•	•
CareTrack via GSM	•	•
Rear view camera	•	•
Side view camera right hand side	•	•
Superstructure		
LED Rear lights	•	•
Service walkway with anti-slip grating	•	•
Centralised lubricating point for slew bearing	•	•
Undercarriage		
2-speed power transmission plus creep speed	•	•
Oscillating front axle ± 9° with out mudguards/ 6° with mudguards	•	•
2-circuit travel brakes	•	•
Maintenance-free propeller shafts	•	•
Hydraulic system		
Load sensing hydraulic system	•	•
Pressure relief system (servo accumulator)	•	•
Proportional controlled visco-clutch cooling fan	•	•
Hose rupture valve for boom and arm	•	•
Hydraulic long life oil ISO VG46	•	•
Cab and interior		
Volvo Care Cab with fixed roof hatch /ROPS	•	•
- Cup holder	•	•
- Door locks	•	•
- Safety glass, light tinted	•	•
- Floor mat	•	•
- Horn	•	•
- Large storage area	•	•
- Pull-up type front window	•	•
- Removable lower windshield	•	•
- Retractable seat belt	•	•
- Windshield wiper with washer and intermittent feature	•	•
Heater & air-conditioner, automatic	•	•
Hydraulic dampening cab mounts	•	•
Adjustable operator seat and joystick control console	•	•
Adjustable steering column	•	•
Hydraulic safety lock lever	•	•
Control joystick, with 5 switches each	•	•
Bluetooth	•	•
Radio with USB	•	•
Cab, all-weather sound suppressed, includes:	•	•
- Operator programable switch on joystick	•	•
- Sun shield, front, roof & rear	•	•
- Master ignition key	•	•
Digging equipment		
Attachment points for extra hydraulics	•	•
Centralised lubrication point	•	•

OPTIONAL EQUIPMENT

	EW180E	EW220E
Engine		
Diesel coolant heater with digital timer	•	•
Block heater, 240 V	•	•
Water separator with heater	•	•
Dust net	•	•
Reversible fan	•	•
Air inlet turbo pre-cleaning system	•	•
Micro- mesh and sealing for engine compartment	•	•
Tropical cooling	•	•
Automatic engine shutdown	•	•
Waste package	•	•
Electric / Electronic control system		
Remote controlled welcome light	•	•
Joystick steering/Comfort Drive Control without steering column (Not homologated for road use)	–	•
Joystick steering/Comfort Drive Control (Road homologated)	•	•
Multi-channel electric centre passage	•	•
Joystick Controlled Support (blade / outrigger function on LH joystick)	•	•
Travel alarm	•	•
LED beacon	•	•
Extra work lights: (LED or halogen)	•	•
- Cab rear 1 and counterweight 1	•	•
- Boom-mounted 2	•	•
- Cab front 2	•	•
LED cab light next to side camera	•	•
4 extra LED lights (2 on cab front extra and 2 on arm)	•	•
Cruise control	•	•
Anti-theft system	•	•
Tilting and rotating attachment preparation	•	•
LED beacon on cab and counterweight	•	•
Superstructure		
License plate preparation	•	•
Off road counterweight	–	•
Road homologated counterweight	–	•
Undercarriage		
Trailer Towing System	•	•
Twin tires 10.00 – 20 / 11.00 – 20	•	•
Single tires 18R – 19.5 / 620 / 40-22.5	•	•
Stone protection rings	•	•
Solid rubber tires 10.00-20 / 11.00-20	•	•
Front dozer blade and rear outriggers	•	•
Rear dozer blade	•	•
Front outriggers and rear dozer blade	•	•
4 outriggers	•	•
Grab holder	•	•
Mudguards, front/rear	•	•
Tool box, left hand side/right hand side	•	•
Drawer type toolbox	•	•
Travel speed 20 km/h, 30 km/h, 35 km/h	•	–
Travel speed : 20 km/h, 25 km/h, 30 km/h	–	•
Wide axle 2.75 m	•	•
Automatic digging brake	•	•
Hydraulic system		
Boom float function	•	•
Boom suspension system	•	•
Hydraulic oil, biodegradable ISO VG32 and ISO 46	•	•
Hydraulic long life oil ISO VG32 and ISO VG68	•	•
Hydraulic equipment for:	•	•
Hammer & shears	•	•
Slope bucket/rotator	•	•
Grab/clam shell	•	•
Quick fit	•	•
Flow control	•	•
Flow and pressure control	•	•

OPTIONAL EQUIPMENT		
	EW180E	EW220E
Cab and interior		
Volvo Care Cab with openable PC roof hatch / ROPS	•	•
Proportional control joystick	•	•
L8 joystick	•	•
Hydraulic proportional pedal for attachment control	•	•
Falling object guard (FOG)	•	•
Cab mounted falling object protective structures (FOPS)	•	•
Rain shield, front	•	•
Sunlight protection, roof hatch (steel)	•	•
Safety net for front window	•	•
Lower wiper	•	•
Anti-vandalism kit	•	•
Second generation Steelwrist tiltrotator preparation	•	•
Volvo Smart View = a 360° camera system with 3 cameras	•	•
Ashtray	•	•
Lighter	•	•
Mechanical Fabric seat, with/or without heater	•	•
Air suspension seat with heater and X isolator	•	•
Luxury operator seat with aico and wide armrest	•	•
Hydraulically elevated cab	–	•

OPTIONAL EQUIPMENT		
	EW180E	EW220E
Digging equipment		
Booms:	•	•
- 5.2 m monoblock	•	–
- 5.47 m 2-piece boom	•	–
- 5.7 m monoblock	–	•
- 5.72 m 2-piece boom	–	•
Dipper arms:	•	•
- 2.45 m, 2.6 m, 3.0 m	•	–
- 2.45 m, 2.6 m, 2.9 m	–	•
- 3.2 m grab arm	•	•
Hydraulic quick fit		
S-type system (S 1 / S70)	•	•
Universal system	•	•
Service		
Wheel chocks	•	•
Tool kit, daily maintenance	•	•
Automatic greasing system	•	•
Attachments		
Buckets, direct fit and quick fit:	•	•
- General Purpose bucket (GP)	•	•
- Heavy Duty bucket	•	•
- Slope bucket	•	•
Lifting eye	•	•
Tilt rotator Steelwrist	•	•

SELECTION OF VOLVO OPTIONAL EQUIPMENT

Trailer towing system



Cruise control



Range of seats



Boom float



Tiltrotator joysticks and monitor



LED lights



Not all products are available in all markets. Under our policy of continuous improvement, we reserve the right to change specifications and design without prior notice. The illustrations do not necessarily show the standard version of the machine.

VOLVO

Volvo Construction Equipment

volvoce.com